

Industrial Gas Turbines utilization with Associated Gases

Géraldine ROY

Lead Market Analyst - Business Development
Siemens Industrial Turbomachinery Ltd

Siemens PG I satisfies customer needs from a single source

Compressor Train

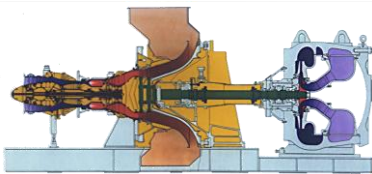
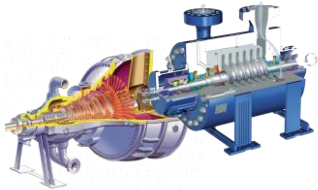

Turbines / Drives

Steam Turbine



Electric Drive

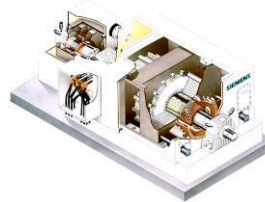

Gas Turbine

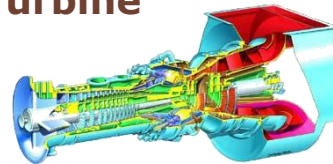

Industrial Power Plants

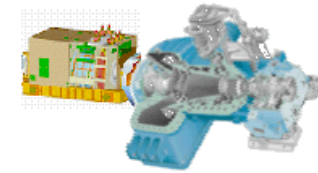

Combined Cycle Power Plants

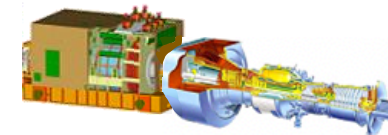

Our Oil & Gas business

Oil & Gas Solutions for ...

Oil and Gas Fields	L N G	On-site Power	Systems Integration
<ul style="list-style-type: none">▪ Gas /oil separation▪ Export (platform)▪ Gas gathering▪ Gas lift▪ Gas injection▪ Water injection▪ Recompression▪ Gas treatment▪ Gas transmission▪ Oil transmission▪ Natural gas storage▪ Oil storage	<ul style="list-style-type: none">▪ Propane▪ MCR▪ Flashgas▪ Boil-off gas▪ Fuelgas▪ E-LNG	<ul style="list-style-type: none">▪ Gas Turbine Gensets<ul style="list-style-type: none">– Simple Cycle– Comb. Cycle▪ Steam Turbine Gensets▪ Mobil power	<ul style="list-style-type: none">▪ Turbo-Compressors▪ Recips▪ Gas Turbines▪ Steam Turbines▪ Pumps▪ Generators▪ Electric motors<ul style="list-style-type: none">– variable speed– fixed speed▪ Process packages

Siemens Gas Turbines

Power Range From 5-340 Mw

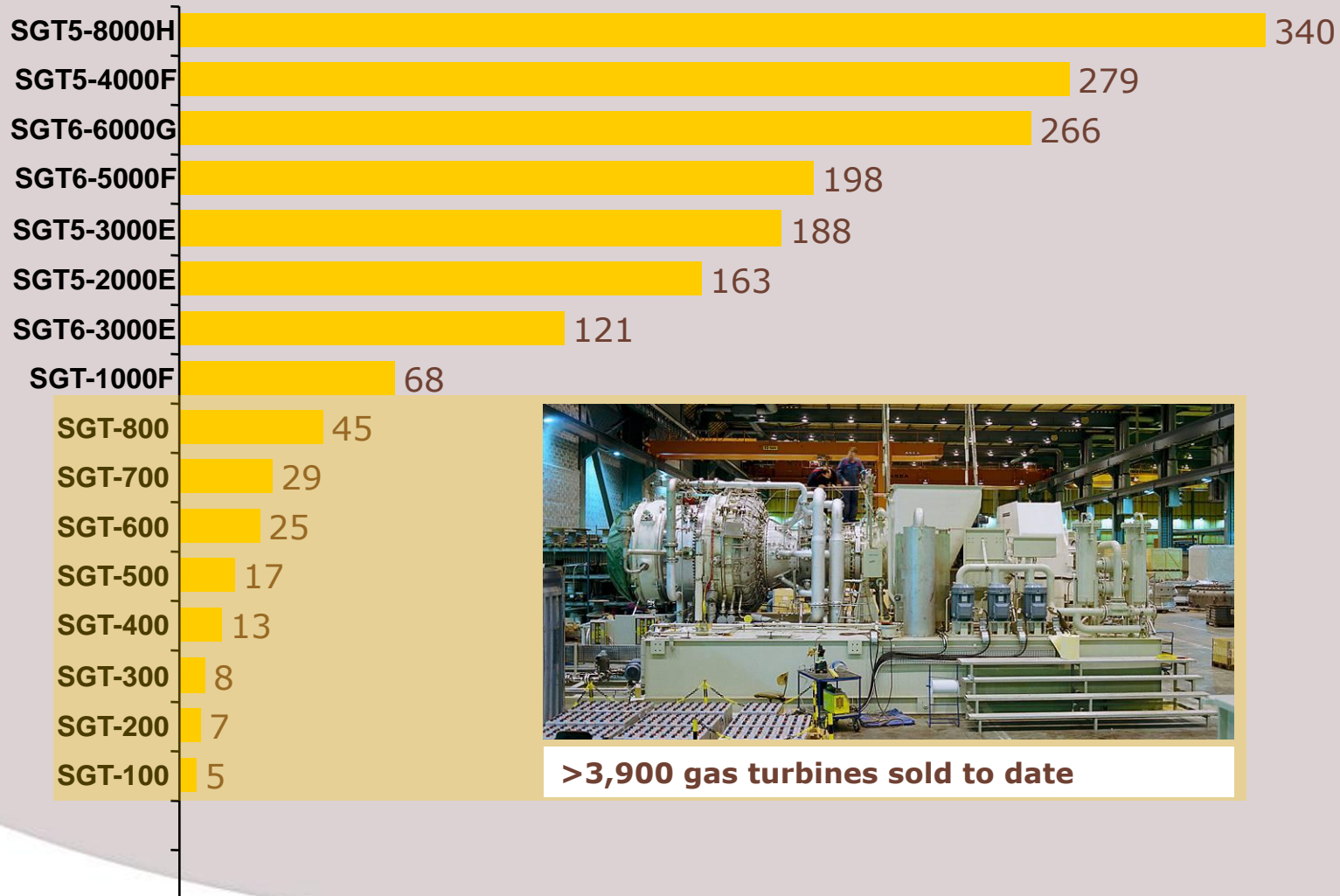

>3,900 gas turbines sold to date

Our Gas Turbines business

Gas Turbines for ...

Power Users

- Chemical/Pharmaceutical
- Petrochemical
- Refineries
- Pulp & Paper
- Food & Beverage
- Ceramics
- Building Complexes
- Textiles
- Automotive
- Metalworking
- Mining
- Cement
- Fertilizers

Power Producers

- Utilities & Municipalities
- IPPs

Oil & Gas

- Onshore & Offshore
- Fixed & Floating installations
- Power Generation
- Mechanical Drive

Fuels For Oil And Gas Up- and Midstream

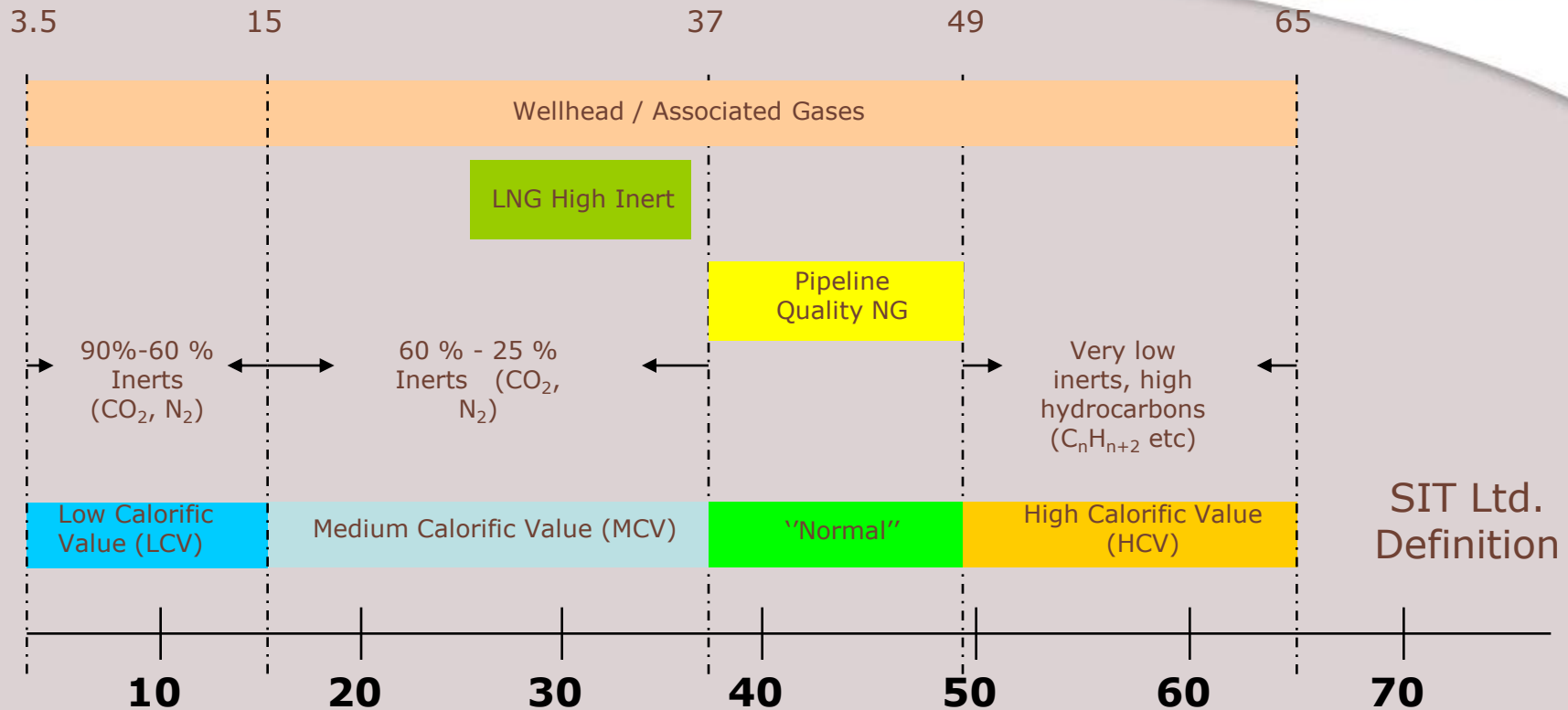

Wobbe Index (WI) is the main indicator of interchangeability of fuel gases.

$WI = \text{Higher heating value} / (\text{square root of gas specific value})$

Wellhead gas and associated gases cover Wobbe Index from HCV to LCV with increasing contents of inert gases ("rare gases")

WI-range of standard pipeline quality gas from 37 to 49MJ/Nm³

Siemens Experience of Non-standard Fuel

Oil & Gas Up- and Midsream Applications

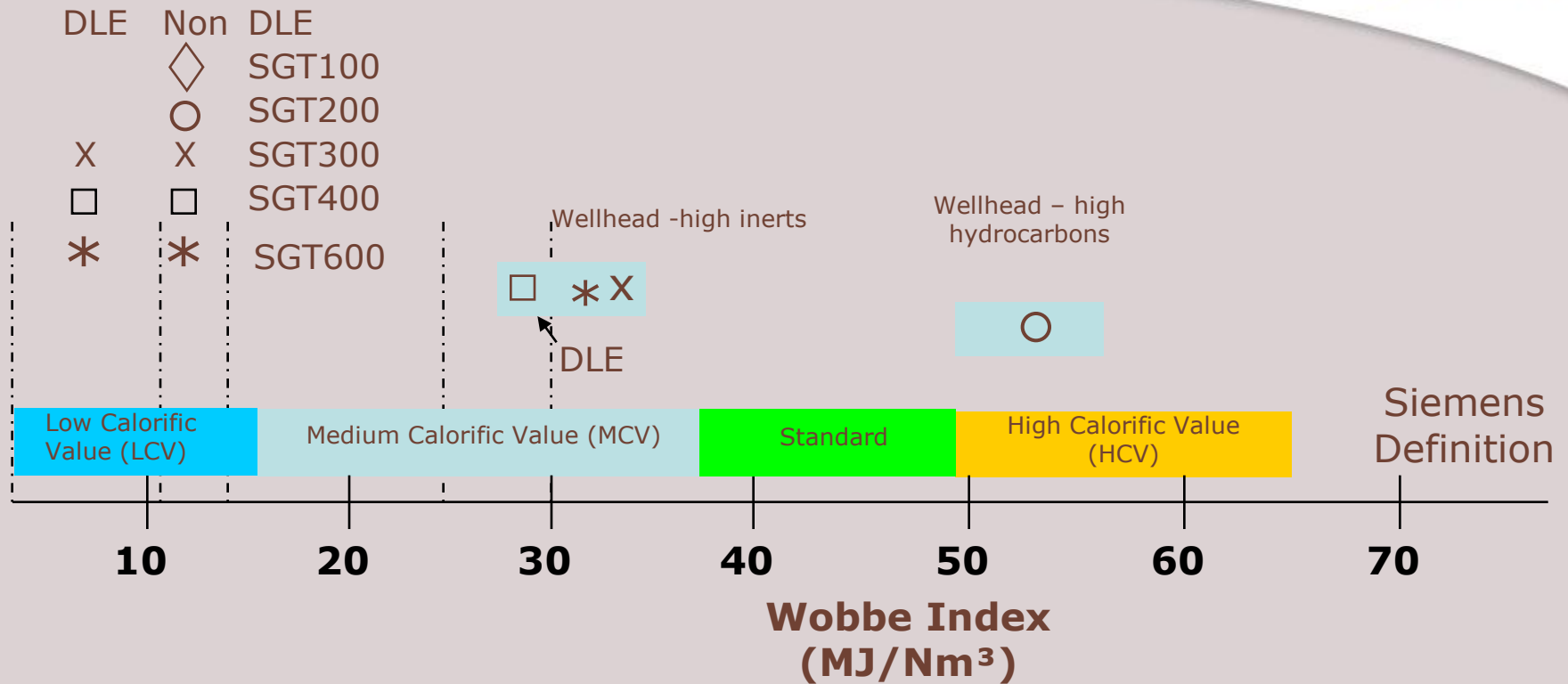

Siemens has experience in selected applications outside standard fuel range using non -DLE combustion system.

A few DLE experiences exist with MCV- fuel

Yadana is an actual order with 2 X SGT400; WI= 28MJ/Nm³

Notes : DLE = Dry Low Emission

Siemens Experience of Non-standard Fuel

Oil & Gas downstream and Industrial Power Generation Applications

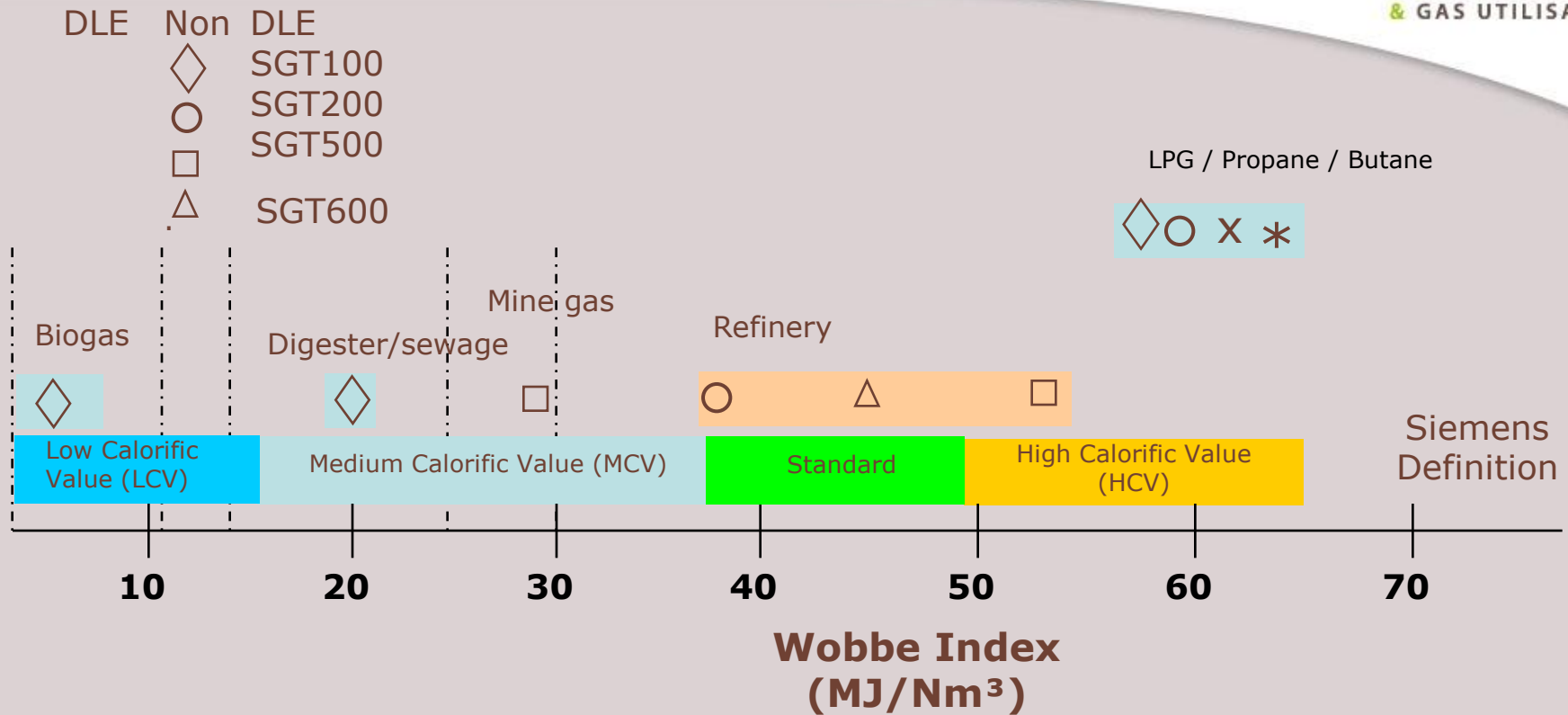

Siemens has experience in selected applications outside the standard fuel range using non-DLE diffusion flame combustion

SGT-100 in CHP for a gas platform

The north sea tidelands - Germany

- Offshore oil field located on the Southern edge of the Wattenmeer National Park
- Gas produced cannot be flared for environmental reasons
- Solution:
 - One SGT-100 gas turbine
 - Output 4.9 MWe
 - DLE combustion system
- First Application of DLE offshore
- “Rich” gas composition with Wobbe Index $>50\text{MJ/m}^3$
- Temperature corrected Wobbe@ 78°C – 48MJ/m^3
- Total DLE hours approximately 59,000 hours
- Significant reduction of emissions : 80-90% reduction of NO_x



SGT-200 for a oil field

Tyanskoe Oil Field - Russia

- First application of its kind in Russia (Western Siberia) burning wellhead gas which was previously flared
- Solution:
 - Three SGT-200 gas turbines
 - Output 6.75 MWe each
 - DLE combustion system
 - Guaranteed NO_x and CO emission levels of 25ppm
 - Min. air temp. (-57°C)
 - Max. air temp. (+34°C)
- Gas composition with Wobbe Index >45MJ/m³
- Total DLE hours approximately 22,000 hours for each unit
- Significant reduction of emissions : 80-90% reduction of NO_x level
- Siemens has supplied >110 gas turbines for power generation, gas compression and pumping duty throughout the Russian & FSS oil & gas industry



SGT-400 for a new gas platform

Yadana gas field - Myanmar

- New platform in the Yadana gas field in the Andaman Sea off the coast of Myanmar
- Solution:
 - Two SGT-400 gas turbine-driven compressor trains
 - Output 13.4 MW each in mechanical application
 - Dual-fuel DLE combustion system
- MCV gas composition with Wobbe Index 28 MJ/m³
- Gas containing up to 24% N₂
- Units will be used to supply gas to the domestic market and to three power plants in Bangkok conurbation in Thailand
- Delivery scheduled for May 2007

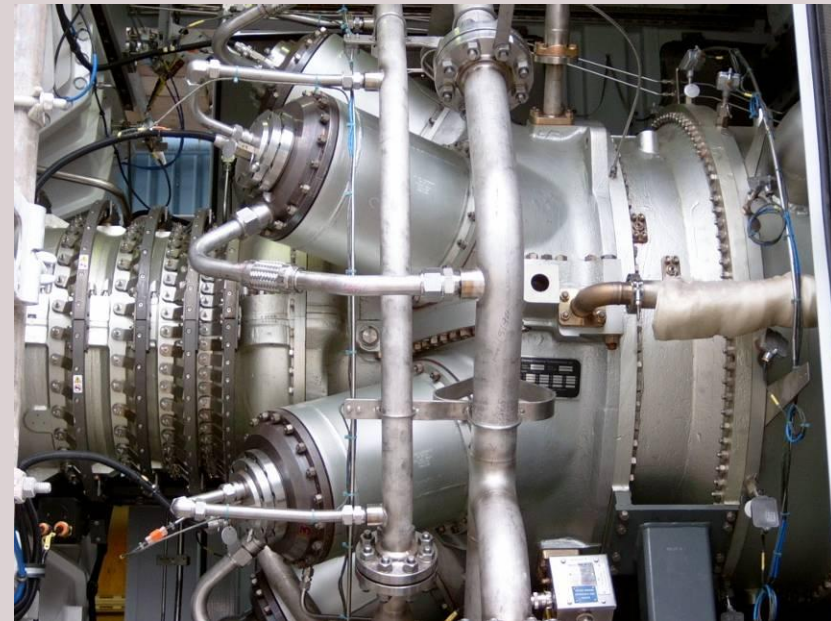

DLE combustion system

Generic across small gas turbines range

Double Skin
Impingement
Cooled
Combustor

Pilot
Burner

Igniter

Main Burner

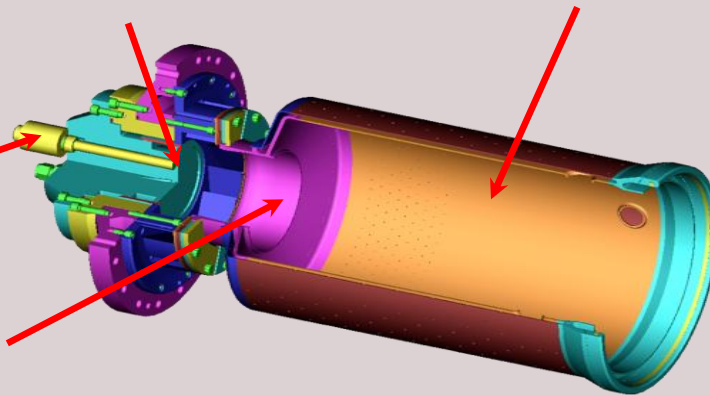

- First DLE unit introduced 1995
- 335 DLE units now in service
- 7,315,000 DLE running hours to date

SGT-100 to SGT-400 Common Design

Emissions Trends

Towards low NOx

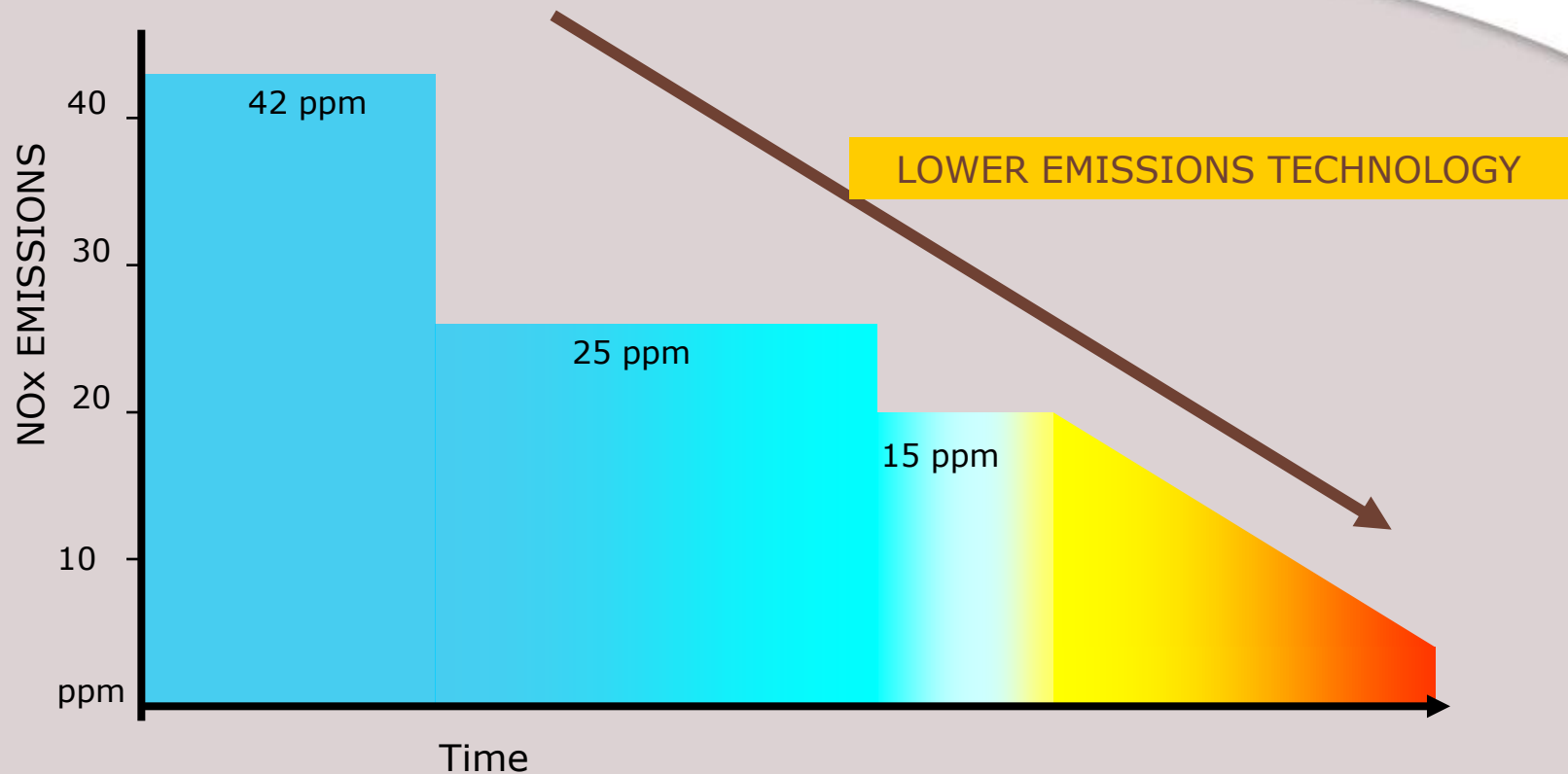

Siemens is committed to develop its DLE technology to reduce emissions and meet market requirements

Summary

- Siemens has experience in selected Up- and Mid-stream Oil & Gas applications with non-standard fuel range and with DLE combustion system :
 - Siemens industrial gas turbines are particularly environmentally friendly and economical thanks to their lower fuel consumption and low emissions
 - Siemens is committed to reducing NOx emissions and continues to develop its DLE technology
 - Fuels outside the range or constituents outside of specifications are handled on a case-by-case basis
- Siemens' strategy is to develop its DLE combustion technology while maximising fuel flexibility, ambient temperature and load range