

# HUMAN CAPITAL FOR A KNOWLEDGE SOCIETY

## HIGHER EDUCATION IN THE MALDIVES

### An Evolving Seascape

Public Disclosure Authorized

Public Disclosure Authorized

Public Disclosure Authorized

Public Disclosure Authorized



THE WORLD BANK



**HUMAN CAPITAL FOR A  
KNOWLEDGE SOCIETY  
HIGHER EDUCATION IN  
THE MALDIVES**  
*An Evolving Seascape*



The World Bank  
Human Development Unit  
South Asia Region

2011 The International Bank for Reconstruction and Development/The World Bank  
1818 H Street, Washington DC 20433, USA  
Telephone: 202-473-1000  
Internet: [www.worldbank.org](http://www.worldbank.org)  
E-Mail: [feedback@worldbank.lk](mailto:feedback@worldbank.lk)

The World Bank Maldives Country Office  
2nd Floor, Hithigasdhoshuge Aage, Hakuraa Goalhi, Henveiru, Male' 20094, Republic of Maldives.  
Telephone: +960 334 1909-10, Facsimile: + 960 334 1911

This volume is a product of the staff of the International Bank for Reconstruction and Development/The World Bank. The findings, interpretations, and conclusions expressed in this paper do not necessarily reflect the views of the Executive Directors of The World Bank or the governments they represent. The World Bank does not guarantee the accuracy of the data included in this work. The boundaries, colors, denominations, and other information shown on any map in this work do not imply any judgement on the part of The World Bank concerning the legal status of any territory or the endorsement or acceptance of such boundaries.

#### *Rights and Permissions*

The material in this publication is copyrighted. Copying and/or transmitting portions or all of this work without permission may be a violation of applicable law. The International Bank for Reconstruction/The World Bank encourage dissemination of this work and will normally grant permission to reproduce portions of the work.

For permission to photocopy or reprint any part of this work, please send a request with complete information to the Copyright Clearance Center, Inc., 222 Rosewood Drive, Danvers, MA 01923, USA. Telephone 978-750-8400, Fax 978-750-4470, [www.copyright.com](http://www.copyright.com)

All other queries on rights and licenses, including subsidiary rights, should be addressed to the Office of the Publisher,  
The World Bank, 1818 H Street NW, Washington DC 20433, USA,  
Facsimile: 202-522-2422, E-mail: [pubrights@worldbank.org](mailto:pubrights@worldbank.org)

#### *Cover Photograph by*

Ms. Mari Shojo

**ISBN : 978-955-8908-42-6**

#### *Produced by*

Ari Investments Limited,  
19, St. Joseph Road, Nugegoda, Sri Lanka.  
E-mail: [ariyaw@sltnet.lk](mailto:ariyaw@sltnet.lk)

# TABLE OF CONTENTS

Abbreviations and Acronyms.....	v
Acknowledgements .....	viii
Executive Summary.....	E1
<b>Chapter One: Higher Education in the Maldives.....</b>	<b>1</b>
Introduction .....	1
The Economic Context .....	1
The Higher Education Sector.....	2
The Global Seascape of Higher Education .....	4
The Higher Education Seascape of the Maldives .....	8
Public Higher Education Institutions .....	9
Private Higher Education Institutions.....	10
The Objective of the Higher Education Policy Note.....	12
<b>Chapter Two: Governance and Quality of Higher Education .....</b>	<b>13</b>
Introduction .....	13
The Governance of Higher Education: Status, Challenges and Policy Options.....	13
The Way Forward: Options for Development.....	18
The Quality of Higher Education: Status, Challenges and Policy Options.....	19
The Way Forward: The Development of a Higher Education Program to Strengthen Governance and Enhance Quality .....	26
<b>Chapter Three: Higher Education Expansion and Diversification .....</b>	<b>33</b>
Introduction .....	33
Public-Private Partnerships in Higher Education.....	35
The Way Forward: Policy Choices for the Promotion of Private-Public Partnerships in the Maldives.....	39
Strengthening The Public Higher Education Institutions.....	43
<b>Appendix A.....</b>	<b>51</b>
<b>Appendix B .....</b>	<b>61</b>
<b>Appendix C.....</b>	<b>63</b>
<b>Bibliography .....</b>	<b>55</b>

## FIGURES

Figure 1.1.	The Structure of the Maldivian Economy, 2010	2
Figure 1.2.	The Tri-Partite Typology of Higher Education	6
Figure 1.3.	Enrolment Shares of the Private Higher Education Institutions, 2009/10	10
Figure 2.1.	The Maldives National Qualification Framework	22
Figure 3.1.	The ISCED Typology of Education	33
Figure 3.2.	Land Subsidies in Male: Components Requiring Coverage	40
Figure 3.3.	Distribution of MCHE Graduates by Type of Academic Award in 2008/2009	44
Figure 3.4.	The Academic Organization and Awards of the Maldives Polytechnic (MP)	48

## TABLES

Table 1.1.	Maldives Higher Education Institutions by Type of Courses and Programs	3
Table 1.2.	Economic and Social Benefits of Higher Education	4
Table 1.3.	Tripartite System of Tertiary Education in Selected OECD Countries	7
Table 1.4.	Gross Enrolment in Higher Education, Maldives and Selected Countries	8
Table 1.5.	Student Numbers in Private Higher Education Institutions (2009/10)	11
Table 2.1.	Programs Offered by the Main Institutions of Higher Education	14
Table 2.2.	Alternative Approaches to Financial Control	27
Table 2.3.	Issues, Main Recommendations, and Key Challenges to Implement the Recommendations	30

## BOXES

Box 2.1.	The Quality Assurance and Accreditation Council of Sri Lanka	24
Box 3.1.	Relevance of Higher Education and Training to Employment, the University of Belize (UB)	45
Box 3.2.	Distance and Flexible Learning (DFL) at the University of South Pacific (USP)	46

# ABBREVIATIONS AND ACRONYMS

ABE	– Association of Business Executive
ACCA	– Association of Chartered Certified Accountants
AHSTC	– Allied Health Services Training Centre
AUQA	– Australian Universities Quality Agency
BTEC	– Business and Technical Education Council
CC	– Cyryx College
CHEA	– Council for Higher Education Accreditation
CIM	– Chartered Institute of Marketing
CIMA	– Chartered Institute of Management Accountants
CMS	– Center for Maritime Studies
COL	– Centre for Open Learning
DHE	– Department of Higher Education
EQA	– External quality assessments
FE	– Faculty of Education
FEC	– Focus Education Centre
FHS	– Faculty of Health Sciences Faculty
FHTS	– Faculty of Hospitality and Tourism Studies
FMC	– Faculty of Management and Computing
FSL	– Faculty of Shari’ah and Law
GCE A/L	– General Certificate of Education Advanced Level
GCE O/L	– General Certificate of Education Ordinary Level
GDP	– Gross Domestic Product
GER	– Gross Enrollment Rate
GNI	– Gross National Income
GoM	– Government of Maldives
HDI	– Human Development Index
HEC	– Higher Education Council
HEI	– Higher Education Institution
HEMIS	– Higher Education Management Information System
IBS	– International Business Systems Overseas
ICT	– Information and Communication Technology
IHS	– Institute of Health Sciences
IMO	– International Maritime Organization
ISCED	– International Standard Classification of Education
MAB	– Maldives Accreditation Board
MAPS	– Modern Academy for Professional Studies
MC	– Mandhu College

MCHE	– Maldives College of Higher Education
MNQF	– Maldives National Qualification Framework
MNU	– Maldives National University
MOE	– Ministry of Education
MP	– Maldives Polytechnic
MQA	– Maldives Qualifications Authority
PAC	– Program Advisory Committee
PPP	– Public-Private Partnership
QAA	– Quality Assurance Agency
QAAC	– Quality Assurance and Accreditation Council
SVHE	– Short-duration Vocational Higher Education
TIOL	– Tertiary Institute for Open Learning

**Vice President**

Isabel Guerrero

**Country Director**

Diaretou Gaye

**Sector Director**

Michael Rutkowski

**Sector Manager**

Amit Dar

**Team Leader**

Harsha Aturupane

**TEAM MEMBERS**

This report was written by a team consisting of Team Leader Harsha Aturupane (Lead Education Specialist, SASSED) and team members, Mari Shojo (Education Specialist, SASSED), John Fielden (Consultant) and Samih Mikhail (Consultant). The peer reviewers were Peter Materu, Lead Education Specialist (AFTED), and Dingyong Hu, Senior Education Specialist (EASH2).

# ACKNOWLEDGEMENTS

A number of individuals in the Maldives assisted and provided valuable information for this study. His Excellency Mohamed Nasheed, the President of Maldives; Dr. Mohammed Waheed Hassan, the Vice-President; members of the Higher Education Council; Ms. Shifa Mohamed, the Hon. Minister of Education, Dr. Ahmed Ali Manik, Minister of State for Education, Dr. Abdulla Nazeer and Mr. Ibrahim Rasheed, the Deputy Ministers of Education, Aamaal Ali, the Permanent Secretary of the Ministry of Education; Ms. Fathmath Amira, the Director-General of the Department of Higher Education, Mr. Ahmed Shafeeu the Director-General of the Department of Planning in the Ministry of Education; and the senior staff of the Ministry of Education (MOE); the Minister and senior staff of the Ministry of Finance and Treasury (MFT); the Minister and senior staff of the Ministry of Human Resources, Youth and Sports (MHRYS); the Department of National Planning (DNP); the Chancellor, Vice-Chancellor and staff of the Maldives National University (MNU); the head and staff of the Maldives Polytechnic (MP); the UN agencies; private higher education and training providers, including from Clique College, Cyryx College, Focus Education Center, Mandhu College, MAPS College, and Villa College; education officials from the Northern Province, including from the Jalaaluddeen School, Afeefuddeen School and Atoll Education Centre; education officials from the Southern Province, including from the MNU Campus and the Polytechnic in Hethadoo, the Mohibudeen School and the Seenu Atoll Education Centre; employers from the public and private sectors; and participants at consultation workshops in Male' and the Addu Atoll.

The authors express their gratitude to Peter Materu, Lead Education Specialist and Dingyong Hu, Senior Education Specialist, for their peer review comments. The team also thanks Anita Fernando (Team Assistant) and Mohammad Khalid Khan (Program Assistant) of the World Bank for providing administrative and editorial assistance for the production and dissemination of this report.

# EXECUTIVE SUMMARY

1. **The Government of Maldives (GoM) is seeking to accelerate human development and economic prosperity within the political framework of a modern liberal democracy.** The government's reform program to achieve this goal, outlined in the policy statement "The Other Maldives" [GoM (2009a)] contains five pillars: good governance to strengthen democratic institutions and processes; expansion and development of human capital; climate change and adaptation; public sector reform to streamline the delivery of services and improve efficiency; and macroeconomic reform to promote private-sector led growth.

2. **The Maldives is seeking to modernize and develop its higher education sector in the face of rising demand for higher education from an expanding pool of young secondary school completers, and increasingly sophisticated skills requirements from employers.** The gross enrollment rate (GER) in higher secondary education rose from 6 percent in 2001 to 10 percent in 2005 to 21 percent in 2011. This GER is expected to rise further in the years to come, with increasing numbers of students enrolling in and completing higher secondary education. In this context, the government has sought the assistance of the World Bank to undertake an analysis of the higher education sector and recommend policy and strategy options, in the light of international good practice and experience, for the future development of the country's higher education system. This policy analysis, which has been prepared through a process of widespread consultation in the Maldives, including with senior policy makers, administrators, academics, employers, public and private higher education providers, principals, teachers, parents and students, presents the results of this analysis and a menu of policy options for the future development of the higher education sector, for the consideration of the government. The Higher Education Policy Study is the first in a series of two World Bank studies. The second study will analyze the policy challenges facing the Maldives general education sector, and present a set of strategic options for the future development of general education, for the consideration of the relevant policy makers in GoM.

3. **Higher education enrolment in the Maldives is low for a middle-income country.** If only university degree level or equivalent enrollment is considered, the gross higher education enrollment rate (GER) is about 6 percent. This is approximately the same GER as countries like Bangladesh, Nepal and Pakistan, which are much poorer than the Maldives and have less developed basic education systems. It is also about half the GER in India and less than a third the GER in Sri Lanka. The main reasons for the low enrollment in higher education are: (a) very limited access to higher education opportunities in the Maldives and (b) poor access to and completion of higher secondary education in the country. Countries at the per capita income level of the Maldives would normally have a larger gross enrollment rate in higher education. For instance, among small, middle-income countries Cape Verde has a GER of 12 percent, St Lucia a GER of 15 percent, and Mauritius a GER of 26 percent.

4. **The Maldives, an enlightened, market-friendly country, contains both public and private higher education institutions (HEIs).** The Maldives College of Higher Education (MCHE) was the main public HEI until February 2011, when it was converted into the Maldives National University (MNU). The majority students in the MNU, however, are at pre-degree level, reflecting its history as a college. The Maldives Polytechnic (MP) is the other public HEI. There are also seven major private providers of higher education courses and programs. Over 95 percent of enrolment in private HEIs are in pre-degree level diploma and certificate programs.

5. **The shortage of degree level programs in the country has compelled Maldivians who wish to study to degree and postgraduate degree levels to seek their university education overseas in a diverse range of countries,** including Australia, England, Egypt, Lebanon, Malaysia, New Zealand, Pakistan, Scotland and Sri Lanka. An important advantage and benefit of this option is that university educated Maldivians are exposed to a rich variety of higher education systems, as well as societies and cultures. A major constraint, however, is that this is an expensive option, particularly if Maldivians are to travel to the high quality HEIs in developed countries such as Australia, England and New Zealand. In consequence, higher education opportunities are severely limited for Maldivians, and there is a shortage of well-educated Maldivians for professional and managerial positions in the economy.

## THE GOVERNANCE AND QUALITY OF HIGHER EDUCATION

6. **Governance and quality are the heart of higher education systems.** Governance typically addresses such questions as the roles and responsibilities of the state and the private sector; the extent and nature of autonomy of institutions engaged in the delivery of higher education services; the protocols and processes for the accountability of the various agencies in the higher education sector; and the management and organization of HEIs. Higher education quality focuses on the framework for quality assurance and accreditation, and the ingredients of quality, such as the quality of faculty programs, curricula, and teaching-learning activities.

### Governance

7. In developed and upper-middle income countries governance mechanisms typically involve:

- A national strategy for higher education that shows what the country wishes to get from its HEIs with some overall policy goals and targets.
- Institutional strategies with targets and Key Performance Indicators (KPIs) that each institution has developed for itself and that have been endorsed and agreed with the government.
- An external quality assurance agency that reviews the quality of the programs delivered by public and private HEIs.

- A funding formula that is related to student numbers and/or outputs and outcomes rather than inputs. This is usually transparent and makes a financial link between resources invested and the performance of the institution. The formula may also incorporate weightings that favour particular subjects, depending on their costs and national importance, or differentiate between modes of delivery and the level of the program.
- Special ‘earmarked’ funding linked to particular policy objectives set by the Ministry of Education (MOE), which can only be used for a particular purpose.
- Financial audits by a national audit office or by authorised professional external audit companies.
- A regular reporting and information system on costs, and outputs and outcomes.

8. **Only some of the normal accountability mechanisms for a higher education system exist at present in the Maldives.** This is due to the fact that, as yet, there is only an embryonic national program for higher education. There is no systematic funding formula, or results focused targets and performance indicators agreed with public HEIs, or a good Higher Education Management Information System (HEMIS). Nor does the MOE set aside funding for policy related programs or performance based funds such as competitive funds. Thus, if the country is to come into line with best international practice there is a considerable amount of work to be done.

9. **The government needs to select from among a rich menu of options available from international practice to meet the current challenges faced by the country.** The appropriate degree of autonomy and accountability of the Maldives National University (MNU), and the role of the Maldives Polytechnic (MP), has to be carefully worked out. In particular, the government now needs to specify whether the MNU will be solely an institution focusing on degree and postgraduate degree programs and research, as is normally the case with a university, and all non-degree programs to be given to the MP and the private sector. The government also needs to develop a program by which the funding for the MNU and MP is linked to the performance of these institutions.

10. **The provision of financial incentives for private HEIs through either support for capital expenditures, or recurrent costs, or both, needs to be decided.** If a decision is made to provide such support to the private sector through such a system of fiscal incentives, the modalities of this relationship, expected performance and outcomes, and the accountability framework have to be set. Alternatively, if students are to be supported through a loan scheme, as the government has commenced to do, then the accountability framework with students, including processes for repayment, has to be established. The government also needs to decide whether resources will be made available to the private sector through competitive funds, and if so, the design and management of such funds.

## Quality

11. **The quality of Maldivian higher education needs to be demonstrably up to international standards.** As a small country the Maldives must be sure that its higher education is of high quality. This means that it is very dependent on establishing international partnerships and links so that it does not lose touch with global standards and developments in higher education. The government should consider ways of achieving this such as:

- encouraging institutions to internationalize (by recruiting staff and students from overseas and arranging staff and student exchanges);
- by sponsoring and promoting international partnerships and linkages and the use of international external examiners;
- by encouraging institutional governing bodies and boards [such as the Maldives Qualifications Authority (MQA)] to have members from other countries; and
- another simple approach would be to benchmark with other countries the entry standards and definitions of pass rates for General Certificate of Education Ordinary Level (GCE O/L) and General Certificate of Education Advanced Level (GCE A/L) examinations.

12. **The Maldives Qualifications Authority<sup>1</sup> (MQA)'s operational mechanisms need to be developed to enable it to fulfil its role effectively.** This would include:

- accrediting new institutions;
- externally reviewing the quality of the programs delivered by all higher education providers; and
- working to strengthen the way that all institutions seek to enhance quality within their normal teaching and learning practices.

## HIGHER EDUCATION EXPANSION AND DIVERSIFICATION

13. **The expansion and diversification of the higher education sector is a key challenge facing the Maldives.** This challenge is the result of several converging factors. First, the demand for higher education is increasing as the proportion of youth in the population who complete secondary education rises. Second, the per capita income of the country is increasing, and the demand for higher education is expanding as the education aspirations of young people grow with greater affluence. Third, employers in the both the public and private sectors are seeking graduates with good skills and competencies for their organizations. Fourth, the delivery of higher education programs and courses is being transformed by global technological changes and economic developments.

---

<sup>1</sup> The Maldives Qualifications Authority (MQA) was created as a semi autonomous body from the former Maldives Accreditation Board (MAB) with several functions.

14. **The Government of Maldives is seeking to diversify and expand its limited range of higher education programs.** This objective requires a combination of policy measures that cover both the private higher education sector and the public HEIs.

**The Maldives has several policy options to promote private-public partnerships in the provision of higher education and training for students.** The main future options are:

- The provision of land on Male' for private higher education providers.
- The payment of subsidies for rented premises to private HEIs.
- Financial grants towards the capital costs of constructing buildings for private HEIs.
- Payment of a subsidy for students enrolled in private HEIs in the form of scholarships, student loans or vouchers.
- Inviting private HEIs to establish campuses in combination with other services: for instance, local and foreign partnerships in medical education and studies, linked with the establishment of hospitals on atolls that would provide health tourism services.
- Allowing academics from private HEIs to compete for research grants under a government research fund on the same terms as academics from the MNU.

15. These different policy options are not in competition or mutually exclusive. The Government could choose to implement more than one, or even several, of these options. It is very important that the incentives provided establish a level playing field for public and private HEIs, and for domestic and overseas HEIs.

16. **The Maldives National University (MNU) will need to develop along multiple paths.** This could include the following.

- The expansion of programs and courses, including e-learning programs and courses, to the various provinces and atolls. This will also require further development of the special types of student support required for e-learning within the MNU system.
- The introduction of new degree programs and courses, wherever relevant and necessary. This could include programs more explicitly targeted at the promotion of modern, liberal democratic ideals, and of programs to support the economic comparative advantage of the country.
- The shedding of non-degree programs and courses, over time. These programs and courses could be left to the Maldives Polytechnic (MP) and to the private sector.
- The generation of research capacity and the production of research output, including journal articles, papers, monographs and books.

17. **The Maldives Polytechnic (MP) will have to develop in ways that enable it to produce graduates who have skills that are relevant in a rapidly evolving and changing labor market.** This would involve the following.

- Strengthening the link with the world of work by having active Program Advisory Committees (PACs) composed of successful practitioners from various sectors of the economy who employ graduates of the MP programs.

- Increasing the use of ICT (Information and Communication Technology) platforms and on-line Internet technologies to support the effective delivery of their programs in the atolls.
- Increasing the capacity, quality and relevance of sub-degree programs in hospitality and tourism studies, construction and fisheries.

# CHAPTER ONE

## HIGHER EDUCATION IN THE MALDIVES

### INTRODUCTION

1.1. **The Republic of Maldives, a middle-income country of extraordinary natural beauty, is one of the most advanced nations in South Asia.** The Maldives consists of an archipelago of nearly 1,200 islands and a population of approximately 400,000 inhabitants; 310,000 Maldivians and 90,000 expatriate workers. More than 25 percent of the population live in Male', the capital, while the rest are distributed among just under 200 other inhabited islands. The Maldives had attained a gross national income (GNI) per capita of USD 5,790 in 2010. This was the highest among countries in the South Asia region. The country ranked 107th in the human development index (HDI) for 2010, which was the second highest HDI rank in South Asia after Sri Lanka. The Maldives also had the second best position among South Asian countries, after Pakistan, in the doing business indicators in 2010, at 85th in the world.

1.2. **The Government of Maldives (GOM) is seeking to accelerate human development and economic prosperity within the political framework of a modern liberal democracy.** The government's reform program to achieve this goal, outlined in the policy statement "The Other Maldives [GOM (2009a)]" contains five pillars: good governance to strengthen democratic institutions and processes; expansion and development of human capital; climate change and adaptation; public sector reform to streamline the delivery of services and improve efficiency; and macroeconomic reform to promote private-sector led growth.

### THE ECONOMIC CONTEXT

1.3. **The Maldivian economy has experienced strong growth over the last two decades.** The GNI for 2010 is USD 5,790 (based on the Atlas method). The economy experienced a growth rate of 9.9 percent in 2010. The tourism sector has been the principal engine of growth in the Maldives. The economy is critically dependent on a small number of sectors, with the following contribution to GDP in 2010: tourism (36%), government administration (13%), construction (8%), real estate (7%), transportation (7%), communication (7%), manufacturing (4%), wholesale and retail trade (4%), and education (3%), and several other relatively small sectors [Figure 1.1]. Transport and communication, and other sectors including trade, construction, real estate, and business services are also linked to the tourism sector. The dominance of tourism in the economy is both a strength and a weakness. On the positive side the demand for tourism, hospitality and leisure services is income elastic, so that as countries grow and household incomes rise, the demand for these services is likely to enjoy strong growth. On the negative side, it makes the Maldivian economy highly

vulnerable to fluctuations and variations in global economic and social conditions through their effect on tourism, and the transmission of these effects to the other related sectors.

**Figure 1.1. The Structure of the Maldivian Economy, 2010**

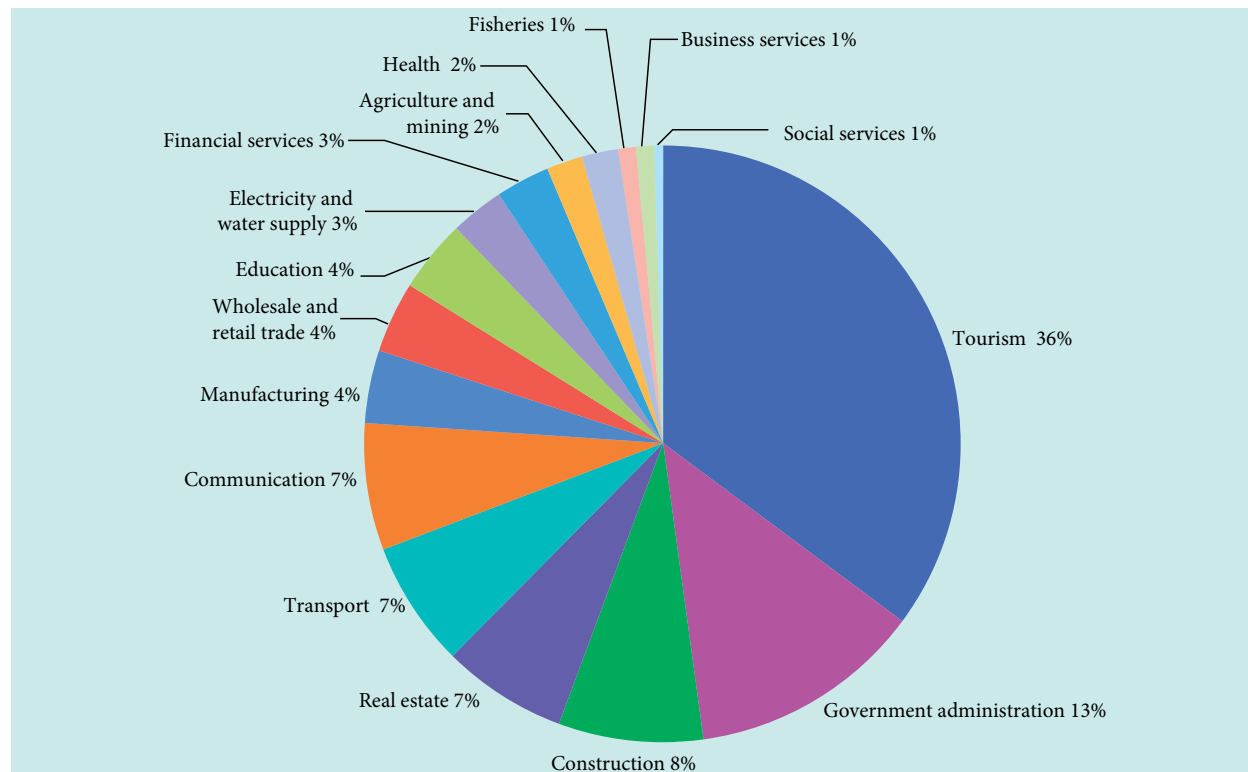

Source: Monthly Statistics July 2011, Maldives Monetary Authority.

## THE HIGHER EDUCATION SECTOR

1.4. **The Maldives, an enlightened, market-friendly country, contains both public and private higher education institutions (HEIs).** The Maldives College of Higher Education (MCHE) was the main public sector HEI until February 2011, when it was converted into the Maldives National University (MNU).<sup>2</sup> The Maldives Polytechnic (MP) is the public sector technical and vocational institute. There are also seven major private providers of higher education courses and programs: Clique College, Cyryx College (CC), Focus Education Center, International Business Systems Overseas (IBS), Mandhu College, Modern Academy for Professional Studies (MAPS) college, and Villa College.

<sup>2</sup> With the creation of the MNU, the Faculty of Islamic Studies, which was a faculty of the MCHE, is expected to become an independent public HEI focusing on Islamic Studies.

1.5. **The structure of the higher education sector in the Maldives is typical of small countries.** The HEIs do not specialize in degree level and postgraduate degree programs in small countries, as they do in large countries. Instead, these institutions offer a variety of courses and programs, at pre-degree certificate and diploma levels, as well as at degree and postgraduate degree level. All Maldivian higher education providers focus mainly on short-duration vocational higher education (SVHE) programs such as pre-degree certificates and diplomas [Table 1.1]. The majority of degree and postgraduate degree/diploma programs that are offered by the MNU and other colleges such as Cyryx, Mandhu and Villa, are accredited and/or awarded by overseas universities. The SVHE certificates and diplomas offered by the various institutions are awarded sometimes by the Maldivian HEIs themselves, and sometimes by overseas HEIs.

1.6. **The shortage of degree level programs has compelled Maldivians who wish to study to degree and postgraduate degree levels to seek their university education overseas in a diverse range of countries,** including Australia, England, Egypt, Lebanon, Malaysia, New Zealand, Pakistan, Scotland and Sri Lanka. An important advantage and benefit of this option is that

**Table 1.1. Maldives Higher Education Institutions by Type of Courses and Programs**

	Public Sector	Private Sector
Postgraduate Degree or Diploma Level Programs	Maldives National University (MNU) (former MCHE)	Cyryx College (CC) Mandhu College Villa College
Degree Level Programs	Maldives National University (MNU) (former MCHE) Faculty of Islamic Studies <sup>3</sup>	Cyryx College (CC) Villa College
Pre-Degree Diplomas and Certificates	Maldives National University (MNU) (former MCHE) Maldives Polytechnic (MP)	Clique College Cyryx College (CC) Focus Education Centre International Business Systems Overseas (IBS) Mandhu College MAPS College Villa College

Source: Records of the MCHE, Maldives Polytechnic and the Private Higher Education Institutions.

3 As noted earlier, the Faculty of Islamic Studies is expected to become a HEI focusing on Islamic studies.

university educated Maldivians are exposed to a rich variety of higher education systems, as well as societies and cultures. A major constraint, however, is that this is an expensive option, particularly if Maldivians are to travel to the high quality HEIs in developed countries such as Australia, England and New Zealand. In consequence, higher education opportunities are severely limited for Maldivians, and there is a shortage of well-educated Maldivians for professional and managerial positions in the economy. In consequence, the country is forced to rely, to a considerable extent, on expatriate workers to staff professional occupations in fields such as medicine, engineering, and teaching, as well as in management positions in service sector operations in tourism, hospitality and leisure services, banking and finance, and transport.

## THE GLOBAL SEASCAPE OF HIGHER EDUCATION

1.7. **Policy makers around the world are increasingly aware of the economic and social benefits of higher education** [Hanushek and Welch (2006)], OECD (2011)]. The Government of Maldives, too, is keenly aware of the benefits of investment in higher education [GOM (2009b)]. The private benefits of higher education are those which are realized by the person being educated. Social benefits accrue to the entire society and spill over even to future generations. These benefits of higher education are summarized in Table 1.2 below.

1.8. As shown in Table 1.2, the economic benefits for individuals include better employment prospects, higher earnings and higher savings levels. For all of society, on the other hand, expanding higher education can promote faster technological catch-up, increase national productivity and then improve a country’s ability to maximize its economic output [Bloom et al (2006)]. Higher education also provides the skilled labor force which is needed for technology transfer and

**Table 1.2. Economic and Social Benefits of Higher Education**

	Economic benefits	Non-economic benefits
Individuals (Private)	Better employment prospects Higher earnings Higher savings levels	Increased responsible citizenship Increase human welfare Improved health and life expectancy
Society (Public)	Faster technological catch-up Increased national productivity Improved economic output Produced skilled labor force	Promoted democracy Better governance Increased political stability Reduced crime Lower state welfare and prison costs Greater and more informed civic participation Social cohesion

technology development, both in terms of specific skills and of general learning ability. As economic production processes have become increasingly knowledge-intensive and technology-intensive in recent decades, the returns to higher education have been rising in many countries [Hanushek and Welch (2006)].

1.9. Education also has non-economic benefits. For individuals, higher education strengthens core values relating to responsible citizenship and care for family and community. Higher education also increases human welfare, and improves health and life expectancy. Studies on the value of higher education outcomes identify a number of public benefits of higher education, including promoting democracy, increasing political stability, reduced crime, lower state welfare and prison costs [Hill et al (2005), McMahon (2009)]. These benefits represent a considerable return although they are difficult to quantify, and thus are significantly important in the context of a country's development. A key public benefit identified by the Government of Maldives, for the future of the country, is the promotion of democracy through higher education [GOM (2009b)].

1.10. **Higher education in modern times includes both the conventional university sector and non-university institutions, which constitute an alternative sector of higher education.** In most countries, both sectors of higher education are facing a number of common challenges, including rising participation rates, changing labor market requirements, and competition for public and private funds. All HEIs have, therefore, to adapt to the increasingly conflicting demands of multiple stakeholders. Students are demanding quality education; employers, education relevant to their needs; and governments, accountability for public resources allocated to educational institutions. Other relevant trends in higher education include the growth of deregulated, market-driven institutions and vocationally relevant programs, together with the development of “seamless” systems of secondary and higher education, vocational training, and lifelong learning.

1.11. **The seascape of higher education has changed and alternative institutions represent distinctive developments in higher education.** They also offer some important benefits-compared to universities-including: (a) easier and more equitable access for large segments of the student population, (b) greater flexibility and responsiveness to the needs of employers, and (c) a different occupational orientation and approach to public service. An effective typology of the higher education system is the so called tripartite system composed of three tiers of institutions: Tier I, which consists of elite research and comprehensive universities; Tier II, lower-status universities and degree-granting colleges and institutes; and Tier III, institutions that offer mostly short-cycle, sub-degree programs (1-3 years). The alternative sector usually consists of all institutions in Tier I and a small percentage of the institutions in Tier II, as shown in Figure 1.2 which outlines the evolution of higher education over the period 1960-2010. The hierarchy of institutions in Tiers I and II is established by the type of degrees offered, the selectivity of admission criteria, and the resources allocated per student. The application of the tripartite system to several leading OECD countries is given in Table 1.3.

**Figure 1.2. The Tri-Partite Typology of Higher Education**

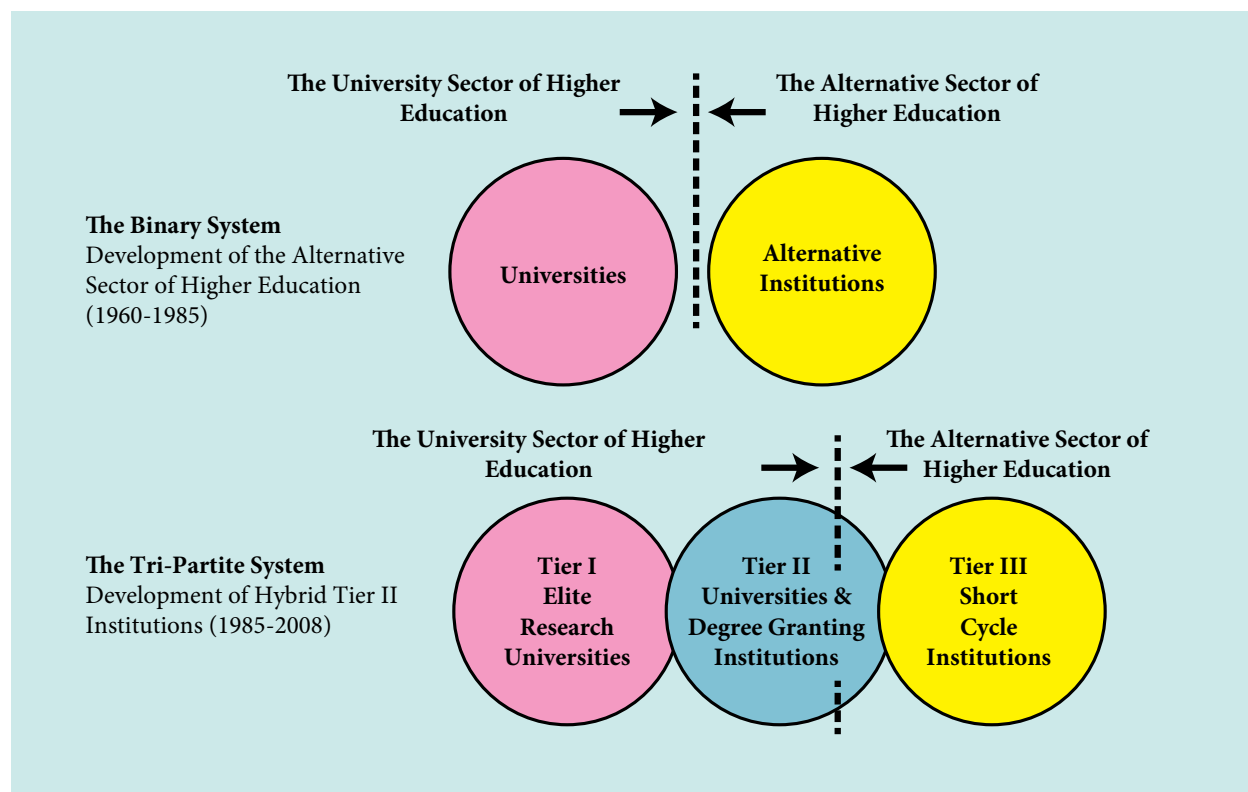

**1.12. The strategic objectives of the alternative sector of higher education are to:**

- provide equity in access to higher education for the growing youth cohort and young adults who would otherwise have no opportunity for higher education;
- provide this access in a cost-effective manner, usually at a lower cost-per-student than in the traditional universities;
- ensure that such education equips graduates with the knowledge, skills, and competencies needed by employers in a fast-changing knowledge economy;
- offer greater flexibility in program design and delivery in order to respond to the complex and diverse needs of students, the labor market, employers, and governments;
- equip students with the learning know-how, abilities, and skills to pursue lifelong learning;
- establish partnerships and bridges to other educational sectors, including general and vocational secondary education, as well as the traditional university sector of higher education; and
- play a meaningful role as an agent of regional economic development in remote regions and/or disadvantaged communities.

**Table 1.3. Tripartite System of Tertiary Education in Selected OECD Countries**

Country	Tier I	Tier II	Tier III
Australia	8 research universities	32 new universities and some TAFE colleges	68 TAFE <sup>a</sup> colleges
Canada	30 research and comprehensive universities	56 new universities, university colleges, polytechnic ITALs <sup>b</sup>	145 community colleges and technical institutes
Finland	20 universities	31 polytechnics	Short-cycle programs in polytechnical education
France	37 Grande Écoles <sup>c</sup>	86 universities	123 instituts universitaires de technologie (IUTs) 280 sections de brevet de technicien supérieur (BTS)
Germany	78 technical and comprehensive universities	182 Fachhochschulen FHS <sup>d</sup> 43 Berufsakademien <sup>e</sup>	Dual training institutes <sup>f</sup>
Ireland	8 universities	13 technical institutes	Training centers
Korea	10 public universities 7 private universities	24 public universities 150 private universities	14 public junior colleges 144 private junior colleges
Mexico	10 federal and state universities 8 private universities	54 state and polytechnic universities 184 private teacher training (TT) colleges 249 public TT colleges	60 technical universities 211 technical institutes 995 private career colleges
Spain	Superior technical schools (Escuelas técnicas superiores)	University schools (Escuelas universitarias)	Higher professional training schools (Formación profesional de grado superior, FPGS)
United States	690 Ivy League, public, and private research universities	1,760 polytechnic, colleges, and smaller state universities	1075 community colleges and institutes of technology

Notes: a Technical and Further Education Colleges.

b Institutes of Technology and Applied Learning, Ontario.

c The Grande Écoles are professional schools, but most are not research-oriented institutions, however, they are the most selective and prestigious institutions in France.

d Fachhochschulen FHS are Universities of Applied Science.

e Berufsakademien are similar to the FHS, but with a strong emphasis on cooperative education

f “Dual training institutes” offer cooperative programs with employers.

1.13. **The Maldivian HEIs fit mainly into the model of Tier III institutions, focusing chiefly on job-oriented alternative higher education although a few HEIs offer some degree programs too.** The Maldives National University (MNU) could aspire to become a TIER II university, shedding its non-degree programs over time to the Maldives Polytechnic and the private higher education colleges. Mandhu College and Villa College, the two private colleges which also prepare students for foreign degrees, also touch the space of Tier II, but are not themselves degree granting bodies to enter this space.

## THE HIGHER EDUCATION SEASCAPE OF THE MALDIVES

1.14. The higher education system (degree or above and pre-degree level) has total enrollment of about 11,000-12,000 students. The Maldives National University (MNU) accounts for approximately 4,500-5,000 students, the Maldives Polytechnic (MP) has around 630 students, and the balance 6,000 or so students are in the various private HEIs. There are some students overseas, too, although the exact number is not known. Students follow a variety of types of programs and courses, including face-to-face instruction, on-line education, full-time courses and part-time courses. If the numbers enrolled in degree level and above or equivalent programs alone are considered, however, there are about 1,700 students in the Maldives.

**Table 1.4. Gross Enrolment in Higher Education, Maldives and Selected Countries**

Country	Higher Education GER (%)	GNI per Capita (USD)
Maldives	3	5,790
Sri Lanka	21	1,990
India	13	1,220
Bangladesh	8	580
Pakistan	6	1,000
Nepal	6	440
Bhutan	7	2,020
Cape Verde	12	3,010
St. Lucia	15	5,170
Mauritius	26	7,240

Source: UNECSO and World Bank Education Statistics. Sri Lanka Higher Education Report World Bank (2009).

Note: All data are for 2010 or nearest available year.

1.15. **Higher education enrolment in the Maldives is low for a middle-income country.** If only university degree level or equivalent enrollment is considered, the gross higher education enrollment rate (GER) is about 3 percent [Table 1.4]. This is a low GER, and below the GER for countries such as Bangladesh, Nepal and Pakistan which are much poorer than the Maldives, and have less developed basic education systems. It is also about one-third the GER in India and well below the GER in Sri Lanka. The main reasons for the low enrollment in higher education are: (a) very limited access to higher education opportunities in the Maldives; and (b) poor access to and completion of higher secondary education in the country. Countries at the per capita income level of the Maldives would normally have a larger gross enrollment rate in higher education. For instance, among small, middle-income countries Cape Verde has a GER of 12 percent, St Lucia a GER of 15 percent, and Mauritius a GER of 26 percent.

1.16. **The higher education sector consists of three main sets of institutions.** Two of these are public institutions: the Maldives National University (MNU), formerly the Maldives College of Higher Education (MCHE), and the Maldives Polytechnic (MP). The third set of institutions consists of a number of private HEIs.

## **PUBLIC HIGHER EDUCATION INSTITUTIONS**

### **The Maldives National University (former Maldives College of Higher Education [MCHE])**

1.17. **The Maldives National University (MNU) was set up in 2011 through new legislation which upgraded the MCHE to university status.** The MCHE itself was established in 1998 to consolidate the existing institutions of post secondary education in the Maldives, which evolved earlier from initiatives in a number of separate ministries including the Ministries of Education, Health, Tourism, Transport and Civil Aviation, and Planning to address their human resource and training needs. In the academic year 2008/2009, there are 4,550 total enrolments. The detailed patterns of enrolment and graduation by the various Faculties and Centers in the MNU (MCHE) are outlined in Appendix A.

### **The Maldives Polytechnic**

1.18. **The Maldives Polytechnic (MP) is an institution of higher education and training which offers a range of programs in engineering technology.** These lead to the awards of certificates, advanced certificates, diplomas and advanced diplomas. The institution was established as a separate entity in 2010, by restructuring and renaming the Faculty of Engineering Technology (FET) of the Maldives College of Higher Education (MCHE) as the Maldives Polytechnic. The Faculty of Engineering Technology was originally established in 1975 as the Vocational Training Centre (VTC) under the Department of Electricity. In 1993, the centre was renamed as Maldives Institute of Technical Education (MITE) under the Ministry of Planning, Human Resources and the

Environment, and then finally as a constituent Faculty of MCHE in 1998. The MP has 614 student enrolments in 2007/2008. A summary of the student enrolment and the number of graduates from the various disciplines and specialties is presented in Appendix A.

## PRIVATE HIGHER EDUCATION INSTITUTIONS

1.19. **There are a number of private providers of higher education programs in the Maldives.** These providers offer courses leading to certificates, diplomas, and in few cases, to degrees. Although a comprehensive institutional classification system has yet to be established, the development of quality assurance guidelines has led to institutional differentiation among these providers; registration as an “Institute” or a “Centre” is less demanding and elaborate compared to a “College”, which requires submission of a detailed proposal outlining the College’s organizational and academic structures.

1.20. The enrollment numbers in the private HEIs are shown in Table 1.5. The shares of enrollment among these institutions are presented in Figure 1.3. The information shows that the majority of enrollment is concentrated in professional, diploma and certificate courses. Degree level enrolment is very small, just 181 out of 5,935 students (3 percent). Cyryx College (CC) has the largest share

**Figure 1.3. Enrolment Shares of the Private Higher Education Institutions, 2009/10**

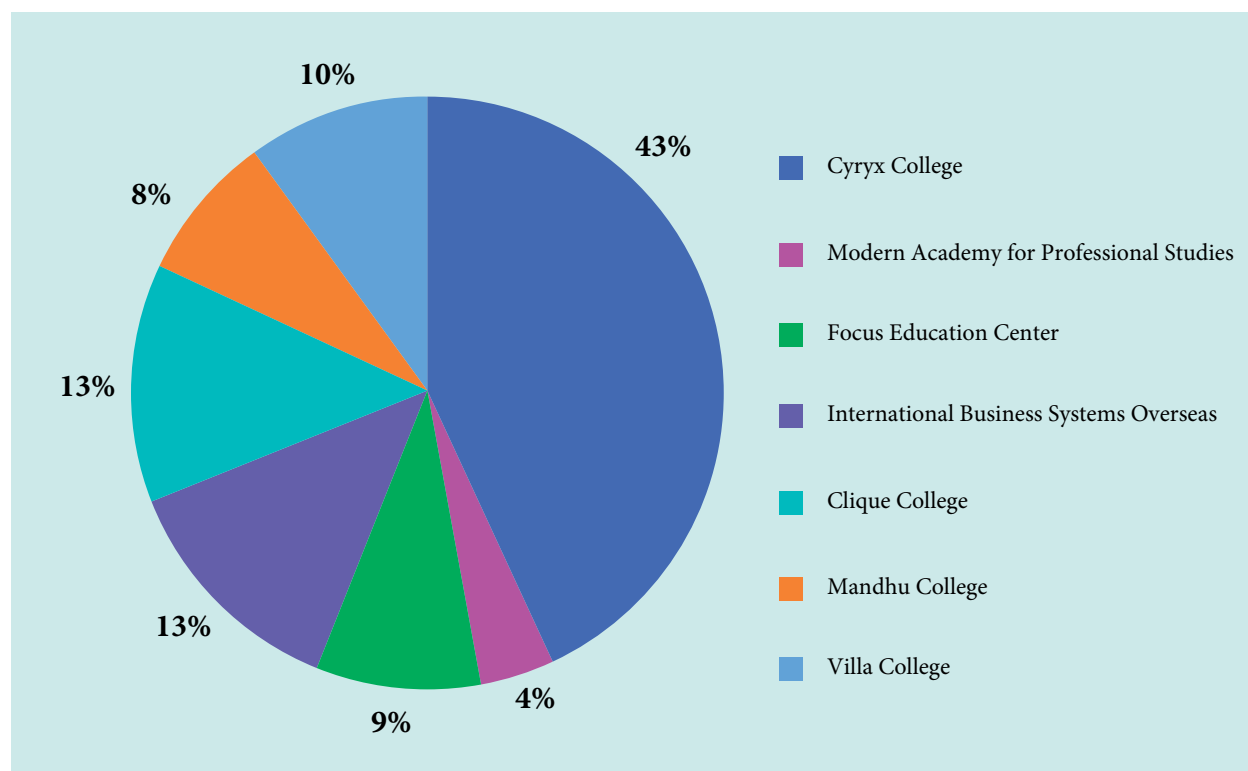

Source: MOE-DHE survey, November 2010.

of enrolment, about 43 percent. The next largest institutions are Clique College and International Business Systems Overseas (IBS). The courses and programs offered by these institutions generally fall within the categories of alternative higher education and are short-term vocational higher education (SVHE), typically lasting from six months to two years in duration [see Mazeran et al (2007) for a discussion of SVHE programs].

1.21. These private HEIs provide programs and courses in fields such as ICT, management and accounting, business administration, and English language. The focus is on job-oriented higher education. Many students are part-time, working during the day and following courses during the evenings. The institutions are all established in Male', although the government would like them to diversify into other parts of the country. Some private institutions have just begun to locate outside Male'. The detailed information of each private HEI is presented in Appendix B.

**Table 1.5. Student Numbers in Private Higher Education Institutions (2009/10)**

Private colleges	Total	Degree Level	Professional a n d Diploma	Certificates and other
Villa College	608	181	263	164
Mandhu College	472*		136	336
Cyryx College	2,557*		286	2,271
IBS	752		103	649
Focus Education Centre	552		117	435
MAPS College	237		237	0
Clique College	757		757	0
Total	5,935	181	1,899	3,855

Source: MOE-DHE survey, November 2010.

Note:\* Mandhu and Cyryx College have some enrolments at the degree and postgraduate degree level. However, enrolment numbers in these programs were not available at the time of the MOE-DHE survey.

## THE OBJECTIVE OF THE HIGHER EDUCATION POLICY NOTE

1.22. This policy note, which has been prepared in consultation with senior policy makers, administrators, academics, employers, public and private higher education providers, principals, teachers, parents and students, serves several purposes. First, the policy note presents a picture of the higher education sector based on technical analysis and factual evidence. This is the first time such an analysis has been undertaken for the Maldives. As such, the report can serve as a vehicle to communicate the characteristics and features of the Maldivian higher education sector to a global audience. Second, the policy note presents and discusses a rich and diverse range of higher education systems, policies and reforms observed in the modern world. The discussion has a special focus on those areas where the Maldives faces its most important higher education policy challenges. Third, based on global and international experience, the policy note presents several policy and program options for the consideration of policy makers and stakeholders. Finally and most importantly, the policy note is intended to provide information and analysis that can be used by the Government of Maldives, and stakeholders and beneficiaries, for the long-term development of the higher education sector in the country.

# CHAPTER TWO

## GOVERNANCE AND QUALITY OF HIGHER EDUCATION

### INTRODUCTION

2.1. **Governance and quality are the heart of higher education systems.** Governance typically addresses such questions as the roles and responsibilities of the state and the private sector; the extent and nature of autonomy of institutions engaged in the delivery of higher education services; the protocols and processes for the accountability of the various agencies in the higher education sector; and the management and organization of higher education institutions (HEIs). Higher education quality focuses on the framework for quality assurance and accreditation, and the ingredients of quality, such as the quality of faculty programs, curricula, and teaching-learning activities.

2.2. The current analysis covers several of the governance and quality issues above. The objective is to stimulate and contribute to the thinking and debate on the national higher education strategy and program in the Republic of Maldives. The emphasis is on the analysis of the current status in the country, the challenges faced, and the presentation of various options for consideration by policy makers and stakeholders in the higher education sector.

### THE GOVERNANCE OF HIGHER EDUCATION: STATUS, CHALLENGES AND POLICY OPTIONS

2.3. **The Higher Education Council (HEC) under the auspices of the President's Office has overall responsibility for national policy on higher education.** The HEC is chaired by the Vice President. The membership of the HEC is made up of Ministers, whose presence reflects the original training institutes that were brought together to create the MCHE. The HEC recommends high-level policies, for both the public and private higher education sectors, to the President and the Cabinet of Ministers. Where changes in legislation are necessary, the policies are presented to the Parliament. The policies that are agreed and adopted by the government are then administered by the Ministry of Education (MOE) through the Department of Higher Education (DHE). The remit of the MOE covers the Maldives National University (MNU) [formerly the Maldives College of Higher Education (MCHE)], the Maldives Polytechnic (MP), and oversight of the rapidly growing private sector higher education institutes and colleges. Table 2.1 lists the principal public and private HEIs in the education system, showing the programs they offer at certificate, diploma and degree levels for students after their General Certificate of Education Ordinary Level (GCE O/L) Examination and General Certificate of Education Advanced Level (GCE A/L) Examination.

2.4. **The government policy framework acknowledges that the private sector has a positive and significant contribution to make to national economic and social development.** The MOE has drafted clauses for regulating private HEIs. Private HEIs are required to register with the MOE. However, the HEC and MOE have not yet defined a clear regulatory framework, nor a process for obtaining regular or complete information on the scale of the private HEIs. A special study in December 2010 by the MOE collected information on the numbers of students studying at public and private institutions and their mode of study. This shows the following approximate picture [Table 2.1].

**Table 2.1. Programs Offered by the Main Institutions of Higher Education**

Public Sector	
MNU (ex-MCHE)	Certificate, diploma, undergraduate degree, BTEC, CIMA, ACCA, Microsoft.
Maldives Polytechnic	Certificate, diploma, CIMA.
Private Sector	
Clique College	Certificate, diploma.
Cyryx College	Certificate, diploma, advanced diploma, degrees.
Focus Education Centre	Certificate, diploma.
MAPS College	Certificate, short courses.
Mandhu College	ACCA, CIMA, CIM.
IBS	Certificate, diploma, advanced diploma, graduate diploma.
Villa College	Certificate, diploma.
	ACCA, ABE certificates and diplomas, Microsoft certificates.
	Certificate, diploma, undergraduate and Master's degrees.

Source: Handbooks of the various higher education institutions.

- There are about 6,000 students in the private sector.
- Only a few private colleges have students at degree level.
- MNU/MCHE and the private colleges each have about 1,900 students working on professional or diploma courses.
- A majority of students in the private colleges are studying at certificate or advanced certificate levels.

2.5. **The Ministry of Education (MOE) has had a long declared aim to upgrade the MCHE to the status of a university.** The University Bill to this effect was passed in the Parliament (Majlis) in December 2010. The President signed the Bill on January 15, 2011. The MNU was formally inaugurated on February 15, 2011. The MCHE has now become the MNU.<sup>4</sup> The MCHE had campaigned hard to achieve this status and produced an action plan in 2008 called *Operational priorities for university title*. This set out the steps needed to match the criteria adopted by the Quality Assurance Agency (QAA) in the UK for the award of a university title. The process described in the QAA's web site is however only partially applicable to the Maldives, since the role of the QAA is to make recommendations to the appropriate UK ministry, which then applies its own rules regarding the award of a university title. There is also an intermediate step in the UK system which is the recognition of an institution's capability to award degrees by granting "Degree Awarding Powers" for taught degrees and research degrees. The legislation enacted for the MNU, in contrast, makes it partly accountable to Parliament and partly accountable to the MOE. This is an unusual arrangement. The MNU budget is recorded under the MOE. The modalities of the relationship between the MNU, Parliament and the MOE will have to be worked out over time.

2.6. **The government will need to develop its own criteria for key characteristics of university status.** The term is not always well defined, but where it is (as in nearly all high income and upper middle-income countries) the criteria for a university relates to the size of student enrolment at degree level, the qualifications of staff, the spread and number of subjects taught, the ability of staff to undertake research, and the academic track record [Salmi (2009)]. The government needs to determine the degree level courses and programs which will be developed in the MNU, rather than being left to the private HEIs. Thereafter, the enrolment in the MNU of students who have successfully completed the GCE A/L Examination and follow degree level courses and programs for the university also needs to be determined. Once this number is decided, the MNU can be given a period of time in which to develop these courses and programs to degree level, including the development of academic staff where needed and appropriate, and to enrol the required number of students. These are key policy options for the government if the MNU is to function as a proper modern university.

### **Governing the Higher Education Sector: the Role of the State**

2.7. The general principles of governance of a higher education sector [see Fielden (2008)] are that the State has the key role in the following areas:

- Deciding the shape and size of the sector. This would involve, for example, the number and types of publicly funded HEIs, and the numbers of such HEIs in the different categories. In the Maldives the decision appears to be that there will be two universities, the MNU and the Faculty of Islamic Studies (Kulliyaa) of the MCHE which will become

---

4 The Faculty of Islamic Studies of the MCHE is expected to become a separate university for Islamic studies.

a separate university for Islamic studies. Currently, the MNU has both degree level and pre-degree level courses. The government needs to decide whether the pre-degree level courses of the MNU will be transferred to the Maldives Polytechnic and/or left purely to the private sector. If such a decision is taken, the government also needs to decide over what period of time this transfer would be made.

- Devising and then implementing a national strategy for the sector that identifies ways in which the State can be assured that its funding is producing graduates with skills that are relevant and of high quality. This will especially apply in the context of the Maldives given the high number of educated young people who search for jobs in the government services rather than the private sector. This is a challenge for many countries in South Asia, as well as in other parts of the world including the Middle East.
- Monitoring or setting the number of students in the sector (in partnership with the Ministry of Finance and Treasury as regards funding).
- Seeking to ensure equitable access for all qualified applicants for higher education.
- Defining the role of private sector HEIs and setting out how they should be regulated.
- Developing a national research and development capacity, where relevant and applicable. This would be particularly important for the Maldives at the current time when the MCHE has been upgraded to the status of a university.

2.8. **These six roles are all applicable to the Maldives and, because of the small size of the sector, should be achievable with minimal bureaucratic process.** In the present structure the high level policy decisions on roles would be principally carried out by the Higher Education Council, and then implemented by the MOE. Operational policy decisions would be carried out by the Department of Higher Education of the MOE.

### **Autonomy and Accountability**

2.9. The degree of autonomy that the MNU has is shown in the checklist in Table C1 of the Appendix, which illustrates those areas where MNU has freedom to operate. It can be seen that this compares reasonably favourably with the other countries shown, but the State still retains all the key powers relating to academic staff salaries and appointments, as well as the appointments of Council/Board members.

2.10. **The MNU has three sources of income: grants from the Parliament (Majlis), tuition fees, and other earnings.** Overall, tuition fees provide about 15 percent of the MNU's income, but in the Faculty of Management and Computing (FMC), which is semi-autonomous, they meet over 60 percent of costs. It is usual in small or developing countries for public HEIs to be heavily reliant on the State for the bulk of their income or on a mix of tuition fees and State income.

2.11. **In any public higher education system the autonomy of institutions is linked to an accountability and regulatory framework.** The aim of such a framework in the Maldives would

be for the MOE to provide assurance to the general public that the MNU and the Polytechnic are achieving the national goals set for them and are operating effectively. At present, the accountability and regulatory framework is still at an infant stage in the Maldives. There are a number of areas that this framework could cover, based on international experience [Woodhall (2007), Saint et al (2009)].

2.12. In developed and upper-middle income countries accountability mechanisms typically involve:

- A national strategy for higher education that shows what the country wishes to get from its HEIs with some overall policy goals and targets.
- Institutional strategies with targets and Key Performance Indicators (KPIs) that each institution has developed for itself and that have been endorsed and agreed with the government.
- An external quality assurance agency that reviews the quality of the programs delivered by public and private HEIs.
- A funding formula that is related to student numbers and/or outputs and outcomes rather than inputs. This is usually transparent and makes a financial link between resources invested and the performance of the institution. The formula may also incorporate weightings that favour particular subjects, depending on their costs and national importance, or differentiate between modes of delivery and the level of the program.
- Special 'earmarked' funding linked to particular policy objectives set by the MOE, which can only be used for a particular purpose.
- Financial audits by a national audit office or by authorised professional external audit companies.
- A regular reporting and information system on costs, and outputs and outcomes.

### **Formula-Based Funding of Higher Education Institutions**

2.13. A funding formula for HEIs, such as the MNU, and for private HEIs if the government decides to enter into private-public partnerships (PPPs) with these institutions using budgetary resources, could be relevant for the following reasons:

- Allocations would be transparent and not open to "personal negotiations".
- Allocations would be logical, fair and consistent across the two institutions. A formula provides stability.
- Resources could be clearly linked to outputs and performance, if so desired.
- Unit costs/units of resources used in the formula could be easily adjusted to achieve efficiency/economy gains.
- In times of hardship the unit of resource used in the formula could be adjusted.
- The allocations can be part of a funding system (combined with tuition fees) and do not need to meet 100 percent of costs.

- 2.14. There are several options to be considered when developing a formula funding model:
- The funding can be allocated on the basis of students completing their programs rather than those enrolling. This rewards success and penalizes institutions that fail to educate their students. However, measures to protect the quality of graduates would need to be instituted, as otherwise institutions may lower standards to pass students and obtain the funds linked to graduation rates.
  - The formula can vary by subject, paying more for expensive disciplines. In the UK there were four price bands (until recently) and there are eight price bands in Australia.
  - The price paid per student can be based on historic cost or a targeted cost.
  - The allocation per student will vary for postgraduate and doctoral students, part-time students, and for those studying online or through distance learning.

2.15. **Only some of the normal accountability mechanisms for a higher education system exist at present in the Maldives.** This is due to the fact that, as yet, there is only an embryonic national program for higher education: in particular, there is no systematic funding formula, or results focused targets and performance indicators agreed with institutions, or a good Higher Education Management Information System (HEMIS). Nor does the MOE set aside funding for policy related programs or performance based funds such as competitive funds. Thus, if the country is to come into line with best international practice there is a considerable amount of work to be done.

## THE WAY FORWARD: OPTIONS FOR DEVELOPMENT

2.16. **The government needs to select from among the rich menu of options available from international practice to meet the current challenges faced by the country.** The appropriate degree of autonomy and accountability of the MNU, and its relationship to the Parliament and the MOE, has to be carefully worked out. In particular, greater clarity is needed on what is meant to be accountable to Parliament and what the role of the MOE would be in terms of funding and performance monitoring.

2.17. **The provision of financial incentives for private HEIs through either support for capital expenditures, or recurrent costs, or both, needs to be decided.** If a decision is made to provide such support for the private sector through such a system of fiscal incentives, the modalities of this relationship, expected performance and outcomes, and the accountability framework have to be set. Alternatively, if students are to be supported through a loan scheme, as the government has commenced to do, then the accountability framework with students, including for repayment, has to be established. The government also needs to decide whether resources will be made available to the private sector through competitive funds, and if so, the design and management of such funds.

2.18. **The development of a balanced framework of accountability and monitoring of the performance of higher education providers will require strengthening of the Department**

**of Higher Education (DHE) of the MOE.** The extra responsibilities on the DHE will require additional skills. This suggests the need for a program of management development for staff, and capacity building of the DHE, since the demands of developing new accountability mechanisms, monitoring, and reporting to the Higher Education Council and the Parliament will place a strain on the existing resources.

## **THE QUALITY OF HIGHER EDUCATION: STATUS, CHALLENGES AND POLICY OPTIONS**

### **Assurance of Quality**

2.19. **A key element in an accountability framework is a process for ensuring the delivery of higher education to a standard of quality that is acknowledged internationally.** Maldivian HEIs, both public and private, should have their awards recognized by universities and colleges throughout the world. One route to widespread recognition could be the adoption of the principles and practices of the Bologna process. A growing number of institutions outside Europe are voluntarily accepting these as a means of enhancing the status of their higher education systems.<sup>5</sup> The Maldives higher education system is based on the UK model, which means that the core element of the Bologna process (the three cycle system of higher education - bachelor's, master's and doctorate) is already in place. Further changes required now would be strengthening the quality assurance regime and the adoption of "Diploma Supplements" for all graduates so as to enhance their mobility into other higher education systems and provide some transparency on what they had achieved in their degree programme.<sup>6</sup>

2.20. **The Maldives higher education system needs to be viewed within the framework of different functions involved in quality assurance and accreditation,** as they can sometimes be confused:

- Before a new private provider can enrol students, it needs some form of recognition by the government. Some countries such as Singapore, Malaysia, Mexico and South Africa, have a hierarchy of processes which separate institutional registration and licensing from accreditation and quality assurance. While the processes of institutional registration, provisional licensing, and full licensing usually look at the institution as a whole, the final accreditation often confines itself to looking at programs. The MQA monitors quality and gives approval to offer courses that meet the competencies of the Maldives National Qualification Framework (MNQF).

---

5 For an outline of the Bologna Process see [http://ec.europa.eu/education/higher-education/doc1290\\_en.htm](http://ec.europa.eu/education/higher-education/doc1290_en.htm)

6 Diploma Supplements are documents that students receive on graduation that provide information on what they have learned. For information on what this entails see [http://ec.europa.eu/education/lifelong-learning-policy/doc1239\\_en.htm](http://ec.europa.eu/education/lifelong-learning-policy/doc1239_en.htm).

- When a foreign provider wishes to establish itself in a country, governments are often unsure how to handle their registration or accreditation. They have a choice – of accepting the institution’s bona fides if it has been recognized and quality assured by a well respected agency in their home country – or of asking the institution to submit to the normal processes followed by domestic applicants. In principle there should be no difference between the treatment of foreign private providers, foreign State-funded providers and new domestic providers. Similar standards of vetting and approval should apply so that there is basis for similar quality standards of provision.
- Some countries have a time limit on accreditation of programs and will expect institutions to re-apply when that limit expires. In the USA this process applies to all public and private institutions as a whole and the voluntary accreditation process is extensive as it involves a scrutiny of a wide range of operational and management processes [see the Council for Higher Education Accreditation (CHEA)]. In the UK there is no accreditation as such, but control over private providers is through giving them degree awarding powers which have to be reviewed after six years by the Quality Assurance Agency.
- External quality assessments (EQAs) are the usual form of check that governments rely on to be assured that institutions are serious about maintaining quality. These EQAs are carried out by a national agency on a cycle ranging from five to seven years and usually focus on the institution rather than an academic program. The standard approach is for the institution to complete a self-assessment exercise (to a standard format), which is then submitted to the quality agency; this is followed up by a team of reviewers who visit an institution and discuss the self assessment. However, governments may also request reviews of specific academic programs where they have concerns.
- A final element relates to Quality Enhancement, which covers the activities and policies that an institution has put in place to promote quality teaching and to carry out regular internal assessments of quality. Although the prime responsibility for quality enhancement rests with the institution, some governments prompt or sponsor activities such as National Teaching Awards or national teaching support centres to help institutions.

**2.21. There are various ways in which small emerging economies can ensure that the quality of their higher education system is in line with global standards.** These include:

- the establishment of national quality assurance agencies (which in small states may have strong links with other regional quality systems);
- encouraging the use of external examiners from other countries;
- provision of funds to support overseas scholarships and PhDs for teaching staff so that they absorb international norms, standards and practices; and
- promoting collaborative partnerships with universities in other countries which can lead to their validation of programs and the exchange of staff and students.

2.22. Apart from the establishment of the Maldives Qualifications Authority (MQA) it is not clear to what extent these measures are being encouraged. As an example the Ministry of Human Resources Youth and Sports (MHRYS) and the Villa Foundation both provide overseas scholarships for staff and students. Up to 400 scholarships are awarded each year by the MHRYS, but the MOE has no information on the number of these that are used to upgrade teaching staff and does not know whether these staff return afterwards to their institution in the Maldives or become part of a brain drain. Information gathering, monitoring and dissemination on issues such as this in higher education is weak, and needs to be strengthened considerably in the Maldives.

2.23. The Maldives Qualifications Authority (MQA) was created as a semi autonomous body in May 2010 from the former Maldives Accreditation Board (MAB) with several functions:

- To develop and then administer the Maldives National Qualifications Framework (MNQF);
- To accredit any new programs proposed by the Polytechnic and private sector HEIs;
- To monitor and assure the quality of all the programmes provided by higher education these institutions; and
- To authorise the entry into the Maldives of any foreign providers of tertiary education through an accreditation process.

2.24. The Maldives National Qualification Framework (MNQF) was established by the Maldives Accreditation Board (MAB) to provide learners, employers, and education providers in the Maldives with a framework that ensures that qualifications are nationally standardized and quality assured. The MNQF incorporates technical and vocational qualifications that provide parity of esteem between these qualifications and academic qualifications, as well as the opportunity for the government to put in place sustainable and strategic solutions for national human resource development needs. The MNQF is based on a modified version of the Scottish Qualifications Framework and involves ten qualification levels from the lowest Level 1, corresponding to Certificate I, a first vocational certificate, to Level 10 that includes several qualifications; the Doctoral Degree, as well as Higher Professional Certificates and Diplomas [see Figure 2.1. In addition, Table C2 in the Appendix gives the details of the framework].

2.25. **The MQA has inherited many of its processes from its predecessor body, the MAB.** The MQA carries out very detailed checks on the study records of each batch of students seeking to graduate from private sector colleges before it authorizes their entitlement to an award. This is highly labour-intensive and imposes a heavy burden on the small staff available to the MQA, and delays the process of quality assurance. This system could be replaced by spot checks on a valid statistical basis or academic audit visits to the colleges to check the reliability of their internal processes and service delivery mechanisms.

**Figure 2.1. The Maldives National Qualification Framework**

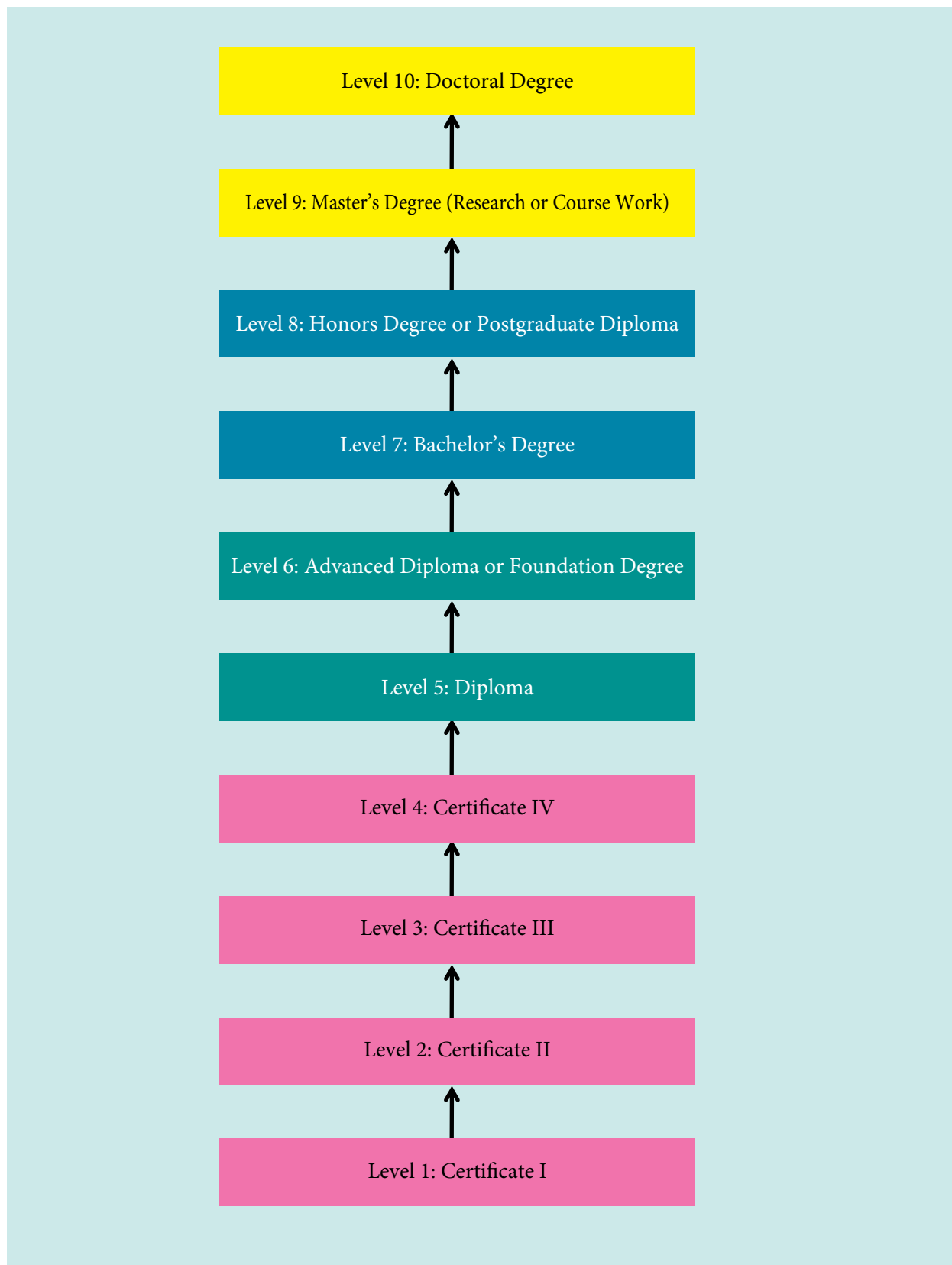

2.26. **The operations of the MQA should be reviewed in the light of international practice in regulation and quality assurance.** It is clear that the combination of a current shortage of qualified staff and the workload from carrying out the present very detailed procedures is preventing MQA from carrying out its more strategic quality assurance and quality enhancement functions. A review of MQA could explore the introduction of a more balanced system, which would include:

- Restructuring the organization so that its three core functions are placed in separate units: the first managing the MNQF; the second applying licensing and accrediting providers; and the third carrying out external quality assurance reviews.
- Changing the role of the MQA so that it is empowered to review institutions as well as programs and to support their internal quality enhancement processes.
- Re-engineering and simplifying the processes involved in approving new programs offered by the private sector. This would remove the MQA's image of being a policeman rather than an advisor and enabler.
- Revising the procedures for licensing and accrediting new tertiary education providers.
- Development of codes of practice and benchmarks against which all academic programs can be assessed.
- Developing processes to operate a programme of periodic "light touch" external reviews of both public and private institutions - using the same criteria and benchmarks.
- Drafting policies and procedures on quality enhancement to be followed by all institutions (and reviewed in the self assessment process).

2.27. **The MQA now has to develop a strategy for the development of its functions and its organization.** This could include a program of professional development – possibly including short-term secondments to overseas quality assurance agencies – and the design of appropriate light touch external review procedures so as to lessen the workload on the staff. The MQA could be encouraged to follow the models and procedures developed by the International Network of Quality Assurance Agencies in Higher Education (INQAAHE) and to join in regional networks such as the Asia Pacific Quality Network (APQN).<sup>7</sup> Partnerships could also be sought from neighbouring countries such as Malaysia or Sri Lanka where the Quality Assurance and Accreditation Council (QAAC) has invested considerable efforts in developing a full range of subject standards and benchmarks and external quality review processes. Participation in some of the subject and institutional reviews undertaken by the QAAC would be an effective form of staff development for reviewers from the MQA.

---

See <http://www.inqahe.org/index.php> and <http://www.apqn.org/>

### Box 2.1. The Quality Assurance and Accreditation Council of Sri Lanka

Sri Lanka has developed a comprehensive process for carrying out quality assurance reviews of universities. This has involved the development of benchmarks and subject standards, the design of self assessment procedures, training university staff as reviewers, and completion of subject and institutional reviews in all the universities. The Quality Assurance and Accreditation Council (QAAC) has also developed the outlines for reviews of postgraduate programs and library facilities and has worked to establish and strengthen networks for internal quality enhancement in each university.

### Quality Assurance of the MNU

2.28. The MNU currently has about 6,000 students (including about 2,000 part timers) who study 150 certificate, diploma and degree level courses. About 70 percent of these certificates and diplomas are at sub-degree level and can be taken by students with adequate O/L, but the MNU's long term plan is to increase the number of degree courses so that they are in a majority. All the current degree programs are validated by overseas institutions. In addition some of the professional diploma and certificate courses offer awards by BTEC, CIMA, ACCA and Microsoft.

2.29. Now that university status has been approved by the Parliament, it is assumed that the MNU will have degree awarding powers of its own. The MNU is keen to emphasize its academic autonomy as regards the maintenance of quality and has established internal policies and processes covering the approval of new programs and examination and assessment processes. For example, one policy adopted by the MNU is the establishment of Advisory Committees in each faculty, with 50 percent of members from outside the College, with the task of reviewing new course proposals and confirming their relevance and the need for them. It is not clear how comprehensive or productive this consultation is, since industry representatives continue to complain about the lack of employable skills in the MNU's/MCHE's graduates.

2.30. **The MOE needs to undertake a review of all the internal and external quality assurance mechanisms within the MNU and recommend any changes in the respective roles of the MQA, the international validating bodies and the MNU's internal quality assurance staff.** Any such review should also review the extent of the MNU's autonomy in academic and financial issues and, having assessed this in the global context, should offer suggestions for change in both delegated powers and mechanisms for the MNU's accountability to the MOE. The existence of independent mechanisms within the MNU for enhancing quality would not be an argument for excluding it from a regime of external self-assessment administered by the state. External reviews are needed to confirm that internal processes and efforts at quality enhancement are working well. Internal and external strands of quality assurance should be complementary, as they are in most universities in the developed world. For example, the Australian Universities Quality Agency (AUQA) states

“AUQA recognizes that the achievement of quality in any organization depends on a commitment to quality within the organization itself, and so operates as unobtrusively as is consistent with effectiveness and rigour.”

2.31. **One crucial step needed to ensure a quality higher education system is to strengthen the capacity of academic staff.** This includes encouraging academic staff to qualify at PhD level. The MNU plans to arrive at a situation where only those with a PhD teach masters level students. The MOE should assess the national stock of teaching staff with masters and PhD qualifications and review the plans of the MNU and the Polytechnic for investing further in academic development. If the MNU is to become an all degree institution, it will require a significant investment in academic staff development, which will need to be phased and planned by the MOE. The Maldives has already obtained academic training from countries such as Australia, India, Malaysia, New Zealand and the UK. However, this has mainly been at degree level, with some masters degrees and a very few PhDs. Upgrading staff to PhD level will require considerable investment of time and resources over a long period of time, and will have to be carefully managed to minimize the risk of brain drain.

2.32. The government will also have to think about the most cost effective ways of providing short-term academic and management development courses in future for academic and managerial staff in the MNU and the Polytechnic. This is most likely to involve the use of foreign staff developers running a tailored program in the Maldives or the participation of Maldivian staff in leadership development programmes run by organizations overseas.

### **International Aspects of Quality**

2.33. **Establishing and maintaining close links with international providers can play a key role in helping a small country such as the Maldives to benchmark its higher education quality against global standards.** It will always be hard for the Maldives to prove that it has applied quality standards objectively, so that international recognition from respected external organizations will be important. Maldivian institutions are already using overseas institutions and professional bodies in various ways:

- To provide franchised course content developed by an international organisation which is delivered locally and then examined to international standards for an international award (e.g., Villa College’s arrangement with the Malaysian Open University, and the professional validations provided by CIMA, ACCA and BTEC).
- To validate local courses as being equivalent to the diploma or degree of the validating body with an examination that is administered by the awarding body. In this model the overseas provider usually provides academic staff development for Maldivian staff or seconds its own academic staff to supplement local academic staff in the initial delivery of some modules of the course.
- To validate local courses as equivalent to the first two or three years of an international course and to offer students at the Maldivian institution a progression to the final year of a degree programme overseas.

## Establishment of Overseas Universities in the Maldives

2.34. **Another model of higher education that is now emerging is where an international provider seeks to establish a campus in the Maldives from which it aims to deliver programmes for the overseas students as well as Maldivian students,** given the small potential student population in the Maldives. The country has already received such inquiries from international HEIs from Italy and India.

2.35. **The MOE will need to develop its regulatory framework for this type of international provider.** For example, to what extent will it expect the MQA to be involved with its provision? How much reliance will it place on the quality assessments of the provider by other national quality assurance agencies in countries such as Australia, India, Malaysia, New Zealand, Sri Lanka and the UK? In addition, it will be important for the Maldives to take a strategic view of requests from international providers and ask whether they are highly regarded in their own country and whether they are among the world's leaders in disciplines of strategic interest to the Maldives. The MOE will need to move away from a reactive mode of merely responding to external requests to a positive one of inviting chosen institutions to express an interest in coming to the Maldives. This model is used successfully in many of the Gulf States, including in Qatar, and also in Singapore. These are, of course, countries which can afford to target some of the world's leading institutions.

## THE WAY FORWARD: THE DEVELOPMENT OF A HIGHER EDUCATION PROGRAM TO STRENGTHEN GOVERNANCE AND ENHANCE QUALITY

2.36. **The program for the higher education sector at present is at an embryonic stage.** Substantial future development of the regulatory framework and the quality assurance system is urgently needed. One possible strand of a future strategy could be for the Maldives to seek out international partners with a global reputation in the academic fields in which the Maldives wishes to build its reputation. If the country relies solely on responding to approaches made to it, many potentially excellent matches could never materialise. The comparative advantage of the Maldives would be in areas such as marine sciences, oceanography, and tourism, hospitality and leisure services.

2.37. **The country needs to develop an approach to funding tertiary institutions that links the national strategic objectives with institutional plans to achieve them.** The usual way that countries follow this model is by using the targets set in the national strategy as a framework within which institutions are asked to plan. Institutions are then encouraged to develop their own strategic plans (adapted to their particular strengths and circumstances), but showing how they will work to implement the national targets. The MOE and the Ministry of Finance and Treasury will

need to develop a medium term budget framework that provides enough funding for the overall strategy to be implemented. This calculation will be based on decisions such as the relative share of institutional income that will come from tuition fees or grants from the State and forecasts for the future numbers requiring higher education in the public sector. A decision will be required on whether to introduce a formula funding model, as described earlier in this chapter, and what version of it to adopt.

2.38. **An appropriate accountability framework for both the public and private HEIs, that focuses on the outputs and results achieved, needs to evolve.** As discussed earlier, funding formulae can be used to encourage the adoption of policy goals; the formulae can also be fine tuned when required. The balance between centralized control and full autonomy in funding is summarized in Table 2.2.

**Table 2.2. Alternative Approaches to Financial Control**

Topic	Centralized Control	Full Autonomy
Annual budgets	Agreed in detail by MOE or the funding body	Agreed by the Board (but possibly reported to the Ministry of Education)
Expenditure	“Line item control” so that institutions cannot switch expenditure between the agreed budget headings	Total freedom to allocate and spend as required within the overall total grant or budget awarded by the Ministry of Education
Under-spending at the end of an accounting period	Surrender all under-spent sums to the Ministry of Education or to the Ministry of Finance	Freedom to carry forward under-spending (and to absorb any over-spending from future funds within limits)
External earnings from non-government sources	Surrender to the Ministry of Education or to the Ministry of Finance all external earnings	Freedom to retain and spend freely all sums earned from non-government sources
Tuition fees for domestic and international students	Fees cannot be charged or, if they are, have to be set at a fixed rate and then surrendered to the Ministry of Finance	Fee levels can be set freely and the money retained without affecting the budget allocation from the government.

Source: Fielden (2008).

2.39. **Another accountability mechanism which the Maldives could consider adopting is to designate special funds that are only used for particular national objectives.** An institution would only be able to use them for that purpose. Once accountability has been assured, there will be a need to consider the extent of financial autonomy that should be given to the new university and the Polytechnic. The system whereby the Ministry of Finance and Treasury exercises detailed control over much of the expenditure could be re-examined and brought into line with that adopted in the other countries where institutions have greater freedom and flexibility.

2.40. **The quality of Maldivian higher education needs to be demonstrably up to international standards.** As a small country the Maldives must be sure that its higher education is of high quality. This means that it is very dependent on establishing international partnerships and links so that it does not lose touch with global standards and developments in higher education. The government should consider ways of achieving this such as:

- encouraging institutions to internationalise (by recruiting staff and students from overseas and arranging staff and student exchanges);
- by sponsoring and promoting international partnerships and linkages and the use of international external examiners;
- by encouraging institutional governing bodies and boards (such as the MQA) to have members from other countries; and
- another simple approach would be to benchmark entry standards and definitions of pass rates for GCE O/L and GCE A/L examinations.

2.41. **Establishing regular reporting systems that will give the government reliable information on student and staff numbers in the system and the costs of the institutions can be very useful, but also challenging.** This, again, is an extension of the accountability and regulatory framework. The government wishes to have a reporting system on both public and private providers, so that the HEC and MOE can have an overall view of the state of higher education. In many countries the MOE has established a Higher Education Management Information System (HEMIS) as an integrated source of information on all aspects of higher education. Such a system usually draws its data direct from institutions so that it is accurate and up to date. This is one option for the government to consider. There are boundary questions as to whether such a system should also collect data on Maldivian students studying abroad (whether on the government and Villa scholarships or on their own account) and on those studying by distance or e-learning. It should be noted, however, that the development and maintenance of a HEMIS can be costly and time and skill-intensive.

2.42. **The MQA's operational mechanisms need to be developed to enable it to fulfil its new role.** These would include:

- accrediting new institutions;
- externally reviewing the quality of the programs delivered by all higher education providers; and

- working to strengthen the way that all institutions seek to enhance quality within their normal teaching and learning practices.

This policy review has identified several areas where the MQA should be encouraged to review its operations, and has also proposed that its role be broadened. How this review is undertaken is an important matter for the government to decide: it could be internally driven by the Board and staff of MQA, or it could use some external inputs from other quality assurance agencies in the Asia Pacific region (or elsewhere) in order to draw on international experience. Given the limited specialist experience on quality assurance issues in the Maldives, a review panel with external members would seem to be desirable.

2.43. **Academic staff and civil servants in the key agencies need to be developed so that they can implement the required changes in the MOE, the MQA and HEIs.** It is clear that if the proposals in this report are followed, an investment in management development and training would be very valuable. There are several ways in which this can be provided:

- commissioning a series of tailored programmes to be run in the Maldives by experienced international providers is one method;
- sending selected senior staff to participate in relevant programmes run by the leading agencies in other countries that train managers in higher education. This is expensive, but has the advantage of enabling networking with participants from other countries; and
- organizing short focused study visits to relevant countries from which the Maldives can learn.

2.44. Issues, main recommendations and key challenges to implement the recommendations are summarized in Table 2.3.

**Table 2.3. Issues, Main Recommendations, and Key Challenges to Implement the Recommendations**

Issues	Main Recommendations	Key Constraints to Implementation and Measures to Address these Constraints
<p>The higher education sector is imperfectly differentiated between university and alternative higher education institutions.</p>	<p>Develop and implement criteria for key characteristics of university status for the MNU and any other universities.</p>	<p>The degree or postgraduate degree level programs and pre-degree programs being offered are currently mixed within the MNU and other HEIs, and it will be difficult for institutions to specialize too narrowly as either universities or alternative HEIs, especially given the small student numbers, for some time to come. This constraint can be relaxed by phasing out the pre-degree programs from MNU and the HEIs over a period of time, as the number of students qualifying for degree level programs increases.</p>
<p>The accountability and regulatory framework is under-developed.</p>	<p>Develop an appropriate governance framework, for both the public and private HEIs, that focuses on the outputs and results achieved.</p>	<p>The Department of Higher Education (DHE) of the Ministry of Education will require considerable expansion of its capacity. This can be achieved through an appropriate program of organizational strengthening and training.</p>

<p>The quality assurance system requires further strengthening.</p>	<p>Review all the internal and external quality assurance mechanisms within the higher education sector, and introduce any changes needed in the respective roles of the MQA, the international validating bodies and the MNU’s internal quality assurance staff.</p> <p>Establish and maintain close links with international QA agencies that can play a key role in helping benchmark the Maldivian higher education system against global standards.</p>	<p>The capacity for QA activities within the Maldives is limited, and linking up with international QA agencies may be costly. The best option would be for QA to be linked with cost-effective international QA systems, especially covering the Asia-Pacific region and small island economies.</p>
<p>The reporting and information system needs to be developed.</p>	<p>Establish a Higher Education Management Information System (HEMIS) that will give the government reliable information on the structure, conduct and performance, of the higher education sector.</p>	<p>The development and maintenance of a HEMIS can be costly, and time and skill-intensive. The HEMIS has to be carefully developed, with appropriate pilot testing, and skills building in the MoE.</p>
<p>Incentives for private HEIs to grow and expand need to be strengthened.</p>	<p>Develop an approach to funding tertiary institutions that links the national strategic objectives of the higher education sector with the plans of individual institutions.</p>	<p>The incentives required by private HEIs, such as land in Male’, can be hard to provide. Also, balancing the interest of existing and new private HEIs, and of domestic and foreign HEIs, can be difficult for the MoE and GoM. The GoM could address this issue by preparing a package of incentives in careful consultation with relevant stakeholders.</p>

The capacity of academic staff and civil servants needs to be developed.

The skills and expertise of academic staff and civil servants in the key agencies need to be developed so that they can implement the required improvements in the MoE, the MQA and HEIs. As an example, the expertise of academic staff in the MNU needs to be developed to enable them to undertake research activities.

Implementing effective human resource development activities will be a challenge. The challenge can be addressed by a long-term human resource development program in connection with reputed universities overseas.

# CHAPTER THREE

## HIGHER EDUCATION EXPANSION AND DIVERSIFICATION

### INTRODUCTION

3.1. **The expansion and diversification of the higher education sector is a key challenge facing the Maldives.** This challenge is the result of several converging factors. First, the demand for higher education is increasing as the proportion of youth in the population who complete secondary education rises. Second, the per capita income of the country is increasing, and the demand for higher education is expanding as the education aspirations of young people grow with greater affluence. Third, employers in the both the public and private sectors are seeking graduates with good skills and competencies for their organizations. Fourth, the delivery of higher education programs and courses is being transformed by global technological changes and economic developments. The current chapter analyzes and presents a set of options for the expansion and diversification of the higher education sector in the country.

3.2. **Higher education programs in most countries are delivered by a diverse variety of higher education institutions (HEIs).** These include both conventional universities and non-university alternative HEIs [Mikhail (2008)]. In addition to the variety of institutional models, the higher education sector also involves work-based cooperative programs and online distance learning schemes. Other relevant trends in the higher education sector include the growth of deregulated, market-driven institutions and vocationally relevant programs, together with the development of “seamless” systems of secondary and higher education, vocational training, and lifelong learning. A useful typology of education that is often used in analyzing education systems is the International Standard Classification of Education (ISCED), which classifies education into seven levels from pre-school (ISCED 0) to the Post Graduate Programs (ISCED 6) as indicated in Figure 3.1. Higher Education in the Maldives involves the following institutional types:

- Remedial programs in private institutions for adult learners needing to complete O/L examinations (ISCED 3B and 4B) ;
- Programs in the Polytechnic and other private institutions that accept students with O/L and lead to the award of certificates and advanced certificates in vocational and occupational subjects (ISCED 3C and 4C);
- Undergraduate programs in the Maldives National University (MNU) and private HEIs leading to the award of diplomas and advanced diplomas in occupational subjects (ISCED 5B); and
- Undergraduate programs in the MNU as well as in private institutions leading to the award of degrees from partner foreign universities (ISCED 5A).

Figure 3.1. The ISCED Typology of Education

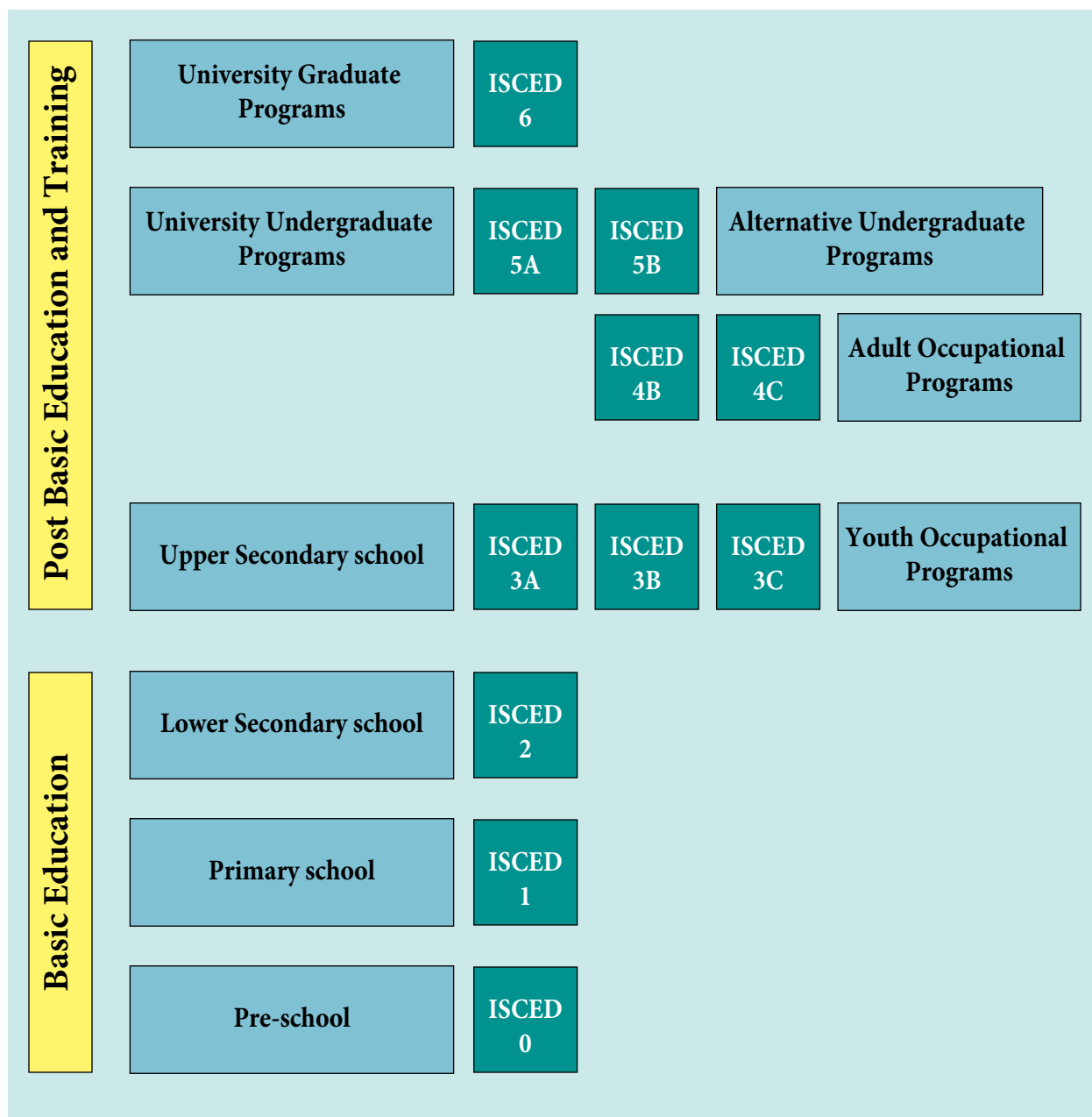

3.3. **The Government of Maldives is seeking to diversify and expand its limited range of higher education programs.** This objective requires a combination of policy measures that cover both the private higher education sector and the public HEIs. The present chapter discusses a series of policy measures that can be adopted, commencing with the stimulation of the private sector, and followed by a discussion of options for the development of the two public sector institutions, the Maldives National University and the Maldives Polytechnic.

## PUBLIC-PRIVATE PARTNERSHIPS IN HIGHER EDUCATION

3.4. **Public-private partnerships (PPPs) in higher education are of central importance for the future development of higher education in the Maldives.** PPPs in the higher education sector can be used for a variety of purposes. The main purposes would be to:

- support socially responsible and sustainable development of the higher education sector;
- expand access to quality higher education to all provinces;
- introduce innovative means of financing and delivering education services;
- improve quality standards in higher education;
- help students and institutions obtain access to financial support; and
- complement public financing and provision to achieve national education goals.

### Private Higher Education Institutions

3.5. **Private HEIs fall into two broad classes, private profit-making HEIs and private non-profit HEIs.** Private profit making HEIs in middle-income countries usually invest in courses and programs that enjoy strong student demand and have relatively low set-up costs. Typically, IT software courses, and management and accountancy courses, predominate. This is currently the case in the Maldives, as with many other developing countries.

3.6. **Private non-profit HEIs normally commence with a specific institutional mandate.** For instance, religious orders may establish HEIs for the academic needs of their membership. Over time, some of these HEIs can develop into institutions that offer a broad curriculum, including the arts and humanities, the natural sciences and the social sciences, and eventually even professional programs such as engineering, law and medicine. Several of the world's most famous universities are private non-profit HEIs, and commenced centuries earlier, many as institutions engaged initially in religious knowledge, philosophy and theology.

3.7. **The participation of private HEIs in higher education has several advantages.** Some of these advantages are common to both non-profit HEIs and profit-making HEIs, while some are relevant only to one or the other of these classes of HEIs. Private HEIs also have some limitations: these are discussed in a subsequent section.

### Advantages of Private Higher Education Institutions

3.8. **The first advantage of private HEIs is that they increase investment in the higher education sector and bring additional resources for expansion and development.** This is particularly important because the unit cost of providing higher education services is considerably greater than the unit cost of providing primary and secondary education services. And expanding access to higher education is necessary for advancement and progress as a country ascends the

ladder of economic development. The demand for good quality higher education rises sharply as a country develops, and the production cost of meeting this demand increases steeply. Even many developed countries, as a result, have introduced policy initiatives to promote private sector participation in higher education during the last five to ten years.

3.9. **A second advantage of private investment in higher education is that private HEIs usually have greater flexibility, and can react to changes in student demand more quickly and efficiently than public HEIs.** This is especially the case for private profit-making HEIs, whose very rationale for existence depends on being able to match the supply of courses and programs to meet the demand from students. Public HEIs, in contrast, usually have less flexibility in changing staff and the organization of courses and programs.

3.10. **A third advantage of private HEIs is that they increase the number, and usually also the variety, of institutions offering higher education services.** When a country has multiple providers and a diversified range of HEIs it expands the choices available for students. This enables students to select courses and programs more closely aligned with their preferences and circumstances. And the country can benefit from the presence of graduates who have a variety of higher educational experiences rather than if all the graduates had a narrow and limited set of higher educational experiences.

3.11. **A fourth advantage is that the presence of private HEIs generates competition, both among the private HEIs and with the public HEIs:** in the case of the Maldives with the MNU. This competition can stimulate improvements in quality in both the public and private HEIs. Also, in the case of private HEIs it can lead to reductions in cost, as the HEIs strive to increase their enrollment numbers and market share. The competition can also act as a spur to innovations in courses and programs, including the introduction of new, market-oriented courses and programs by the HEIs.

3.12. **A fifth advantage is that if the private higher education sector takes-off and grows vibrantly, it can become an important source of economic revenue to the country.** This is particularly the case if foreign students can be attracted to the HEIs based in the Maldives. Private HEIs, due to their greater flexibility and adaptability, are more likely to be able to attract foreign students. For example, where private HEIs are linked with overseas partners, or are in-country franchise operations of a reputed HEIs in a developed country, international students from other countries, especially the neighborhood of the Maldives, could well be attracted to take advantage of the higher education opportunities available in the country. The private HEIs seeking to attract foreign student could seek to use the natural beauty of the Maldives creatively in their campuses, in order to attract foreign students and researchers.

3.13. **A sixth advantage is that the expansion of private HEIs can generate job opportunities for bright young Maldivians, as academics and researchers, as well as in managerial and administrative positions, in the HEIs.** If HEIs campuses can be established in a viable manner in strategically selected atoll centers, then the government’s policy objective of developing provincial economic centers can also be facilitated, as the presence of HEI campuses generates demand in the locality for a variety of goods and services, including accommodation and food, cultural and social activities, and ancillary services.

### **Limitations of Private Higher Education Institutions**

3.14. Private HEIs also have limitations, which can be perceived as disadvantages from certain perspectives. These limitations, the perspectives from which these are considered disadvantages, and some responses, are described below.

3.15. **Private HEIs in small developing countries such as the Maldives, especially when they are new, typically do not engage in courses and programs that have high set-up costs.** Hence degree programs in, for example, heavy engineering would not normally attract private HEIs. Also, for-profit HEIs do not engage in courses and programs where student demand is low, but which are of importance for the intellectual and cultural lives of the country. For instance, courses in several varieties of the arts and humanities, and the social sciences, and even the natural and social sciences, may not attract adequate private investment. The only exception would be non-profit private HEI’s which may engage in a few areas within their institutional mandates. But these HEIs may not be able to offer a full range of liberal arts type programs in the Maldives, given its small student numbers.

3.16. **Private HEIs, particularly some profit-making HEIs, may also offer courses and programs of poor quality.** The drive to reduce costs and generate profits can cause private HEIs to operate with poor physical capital, especially facilities and equipment, as well as to reduce the quality of staff. This has not been a major problem in the Maldives thus far, mainly because there are a small number of private higher education providers, nearly all of whom concentrate on a limited range of vocational higher education courses, with only partial emphasis on academic higher education. But it could become a problem if the private higher education sector were to expand in the future. The optimal policy response to this problem is to set up a strong quality assurance and accreditation agency that can safeguard standards and facilitate the entrance and operation of good quality private HEIs.

3.17. **Private profit-making HEIs may be “footloose”, and might close down leaving students stranded in mid-program.** This does not appear to be a major risk in the Maldives at present, as the current private providers are reputed and responsible institutions. But some degree of risk needs to be recognized, especially if the private HEIs engage in typical three and four year degree programs. The appropriate policy response, once again, is to ensure that all private HEIs operate within the umbrella of the quality assurance and accreditation agency.

3.18. **Another criticism of the private HEIs, especially for-profit HEIs, is on equity grounds.** Private profit-making HEIs normally cater to students from wealthier households, when intelligent students from less affluent homes may be unable to pay the fees required to enjoy the benefits of higher education in these institutions.

3.19. Countries can respond to this limitation in several ways. First, the government could make some means-tested scholarships available in the private HEIs for bright but poor students. Second, the HEIs can themselves be requested to set aside a percentage of places at a subsidized cost for such students. Third, the government could take the position that the public HEI, the MNU, would take care of the demand from less affluent students, so that at the national level there is equity of access and opportunity.

3.20. **There is also concern in some countries that private, non-profit HEIs may have institutional mandates that are not consistent with the social, cultural and political goals of a country.** This does not appear to be a problem at present in the Maldives. However, policy makers could provide adequate safeguards that, for instance, private HEIs work within institutional mandates that are consistent with the principles and norms of modern liberal democracies.

3.21. A further criticism levied against opening the higher education sector to private sector participation, in some countries where higher education is either solely or nearly a public monopoly, is that the private HEIs will offer better benefit packages and attract the best academics away from public HEIs, thus weakening the latter. This criticism or fear is usually unwarranted in practice. When countries open up to the private higher education sector at first some academics in public HEIs may teach in the private HEIs on a part-time basis, but there is no mass drain of talent from public HEIs to private HEIs. Academics prefer to stay in public HEIs for a variety of reasons, including greater job security and time for research and other activities. Over time, as the private HEIs become better established, some academics may move from the public HEIs to the private sector. However, this process creates opportunities for bright and well-educated young individuals to become academic in the public HEIs. Overall, the employment opportunities available for academics increase.

## THE WAY FORWARD: POLICY CHOICES FOR THE PROMOTION OF PRIVATE-PUBLIC PARTNERSHIPS IN THE MALDIVES

3.22. **The Maldives has several policy options to promote private-public partnerships (PPPs) in the provision of higher education and training for students.** The main options, and their advantages and disadvantages, are outlined below.

### *Policy Option One*

3.23. Provide land on Male' for private higher education providers.

*Advantages.* This is the principal demand of private HEIs. The demand for higher education is experienced mainly in Male', as most potential students live on Male' and do not want to travel to locations outside the island. Land in Male' is expensive and limited. And private HEIs need to invest considerable resources in the construction and refurbishment of buildings, and in fixed equipment, to deliver education services. If private HEIs are assured of land, for example through long-term leases or freehold ownership, the investment required would be worthwhile. However, if land is available only on short-term leases, the HEIs face considerable investment risks, and are reluctant to invest substantial resources in construction and fixed equipment.

3.24. The government is also seeking to promote balanced regional development on the atolls by encouraging private HEIs to locate on these atolls, perhaps in the provincial centers. However, private HEIs state that there is insufficient demand on the atolls for their operations to be financially viable. But if they are given land on Male', the profits made through the Male' operation would enable them to subsidize operations on the atolls.

*Limitations.* Land on Male's is extremely scarce, and in high demand from a variety of sources. Devoting some land for private HEI's would have an opportunity cost in terms of alternatives foregone.

3.25. A spider graph of this option, and the components it would need to cover such as land, quality assurance and accreditation, are given in Figure 3.2.

**Figure 3.2. Land Subsidies in Male: Components Requiring Coverage**

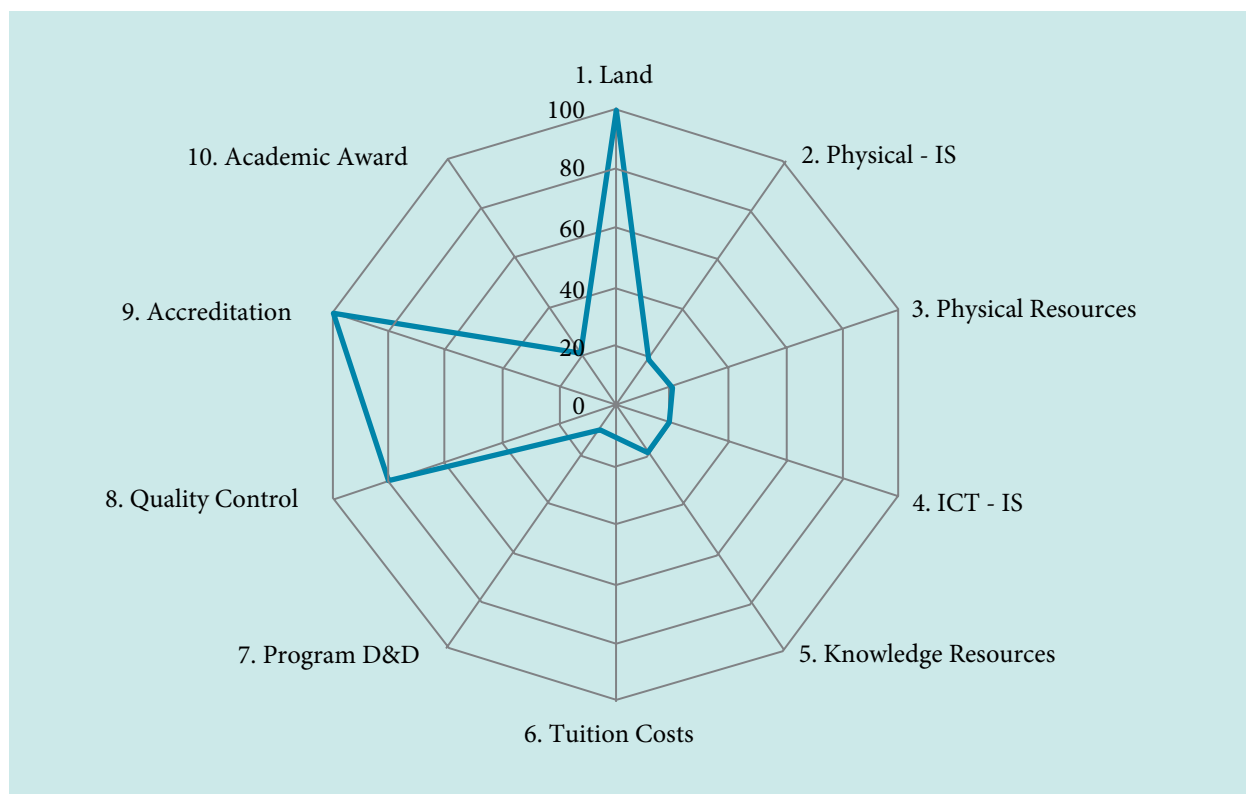

### ***Policy Option Two***

3.26. The payment of subsidies for rented premises. Such subsidies can play an important role in encouraging private HEIs where available land is scarce and expensive, as in Male.

*Advantages.* This would reduce the costs and be an incentive for private HEIs to set up. It would also facilitate non-profit oriented private HEIs, which may not offer courses with the same revenue raising opportunities as profit-making private HEIs.

*Limitations.* There would not be a level playing field between investment in higher education and other investment choices faced by the private sector.

### ***Policy Option Three***

3.27. Financial grants towards the capital costs of constructing college or university buildings.

*Advantages.* This would provide a substantial incentive for a private HEI as the capital costs of construction are high. Non-profit private HEIs would particularly benefit. In order for the full benefits to be realized, the land on which the buildings are constructed or refurbished would need to be given on a sufficiently long lease or freehold.

*Limitations.* Once again, the playing field between investment in higher education and other potential private sector investments would not be even.

#### ***Policy Option Four***

3.28. Payment of a subsidy for students enrolled in private HEIs. This could be in the form of scholarships, student loans or vouchers.

*Advantages.* The cost of payment for students would be reduced (scholarships, vouchers) or deferred (loans). It would also promote competition among HEIs if the students who are entitled to the subsidy could carry the financial benefit to whichever HEI they chose. Competition could be extended to public HEIs (e.g. the MNU) if students were entitled to this financial benefit in either the MNU or the private HEIs, and could select between either set of institutions. Student loan systems have been successful in countries such as the U.S.A. where students can obtain loans from Banks, and in Australia.

*Limitations.* Student loan systems are difficult to administer in economies that have not acquired the culture of financing higher education through borrowing. Two key conditions for success are that the government should be in a position to track graduates income accurately and have an effective loan collection mechanism. Where these two conditions are not met, repayment rates are very poor. It is unclear whether the Maldives would be able to design and implement an effective mechanism for collection, so this is an important limitation for the country.

3.29. Scholarship schemes can be inequitable if they are awarded on the basis of performance at public examinations, rather than economic need. Voucher systems are promising, but require a drastic change in the culture of HEIs, particularly public HEIs (such as the MNU), and can be difficult to implement fully, or except over a long period of time. With voucher schemes it is also important that weaker institutions receive considerable support in the form of capacity building.

#### ***Policy Option Five***

3.30. Invite private HEIs to establish campuses in combination with other services. For instance, it could be possible to invite local and foreign partnerships in medical education and studies, linked with the establishment of hospitals on atolls that would provide health tourism services.

*Advantages.* Measures such as these could both expand the higher education sector and link it with economically attractive activities. There would be a direct benefit to the economy as well as the higher education sector.

*Disadvantages.* There are likely to be a limited number of such opportunities that are viable over the long-term.

3.31. However, where such opportunities do exist, they can and should be exploited. The government could either respond, on a case by case basis, to HEIs that express an interest in this type of collaboration. Alternatively, the government could invite proposals for such partnerships, perhaps through international tenders.

### ***Policy Option Six***

3.32. A research fund is established by the State. Academics from private HEIs are allowed to compete for research grants under this fund on the same terms as academics from the MNU.

*Advantages.* Research funding can stimulate research, which in turn is positively related to the quality of teaching, as active researchers are more likely to be up-to-date with their academic knowledge than non-researchers. It would also stimulate some HEIs to be centers of excellence in areas where the country has a comparative advantage, such as environmental and marine resources, climate change, and tourism. The research output could also be of benefit to the government, through the contracting of policy research from academics in the HEIs, and to private sector firms. A high quality research system in specialized niche areas could even attract foreign researchers and research grants to the country, as well as contracts from overseas private firms, in the long-run.

*Limitations.* The Maldivian higher education system is not yet developed enough for high quality research programs. And the mass of academics available is very small.

3.33. As such, this would be more a long-term option, with carefully targeted support for research in selected areas, and where Maldivian academics link with overseas academics and researchers in joint research programs.

### ***Combinations of Policy Options***

3.34. Finally, it should be noted that these different policy options are not in competition or mutually exclusive. The government could choose to implement more than one, or even several, of these options. It is also very important that the incentives provided establish a level playing field between public and private HEIs, and for domestic and overseas HEIs.<sup>8</sup>

---

<sup>8</sup> During consultation for this report, some private HEIs requested that existing HEIs should be given preferential support by Government in relation to potential new HEI's seeking to enter the market. This is a policy matter for the Government of Maldives to decide.

## STRENGTHENING THE PUBLIC HIGHER EDUCATION INSTITUTIONS

3.35. **The Maldives has several development options to strengthen the public HEIs.** These are the Maldives National University and the Maldives Polytechnic.

### THE MALDIVES NATIONAL UNIVERSITY (MNU)

3.36. **The MNU is an embryonic university.** The MNU was formed in February 2011, and emerged from the Maldives College of Higher Education (MCHE). As the name indicates the MCHE was more comparable to a community college than a university in terms of its range of program offerings, and the numbers of graduates in various academic award categories, including certificates, advanced certificates, diplomas, advanced diplomas and degrees. As Figure 3.3 indicates only two faculties at MCHE had more than 15 percent of their graduates at the degree level in the academic year 2008/2009, namely the Faculties of Shari'ah and Education. The percentage of graduates with degrees from the Faculty of Management and Computing was 13 percent and from the Faculty of Hospitality and Tourism Studies was zero. This low level of graduates with degrees in a growing knowledge economy, and in two important sectors of the economy, represents a key challenge for the government.

3.37. The MNU needs to be further developed to offer higher education opportunities, particularly in geographical areas that the private HEIs may not reach despite the provision of incentives, and in subjects and disciplines that are important for the country, but not sufficiently market-oriented to attract private HEIs. A key policy for the MNU to consider is to improve the capacity, quality and delivery of on-line and distance education, including e-learning and m-learning [see Box 3.1 for an example of a university from a small country, Belize, with strong investment in on-line courses and programs].

3.38. **The Maldives National University (MNU) will need to develop along multiple paths in the future.** First, the further development and expansion of e-learning courses to the various provinces and atolls, with a focus on quality and relevance. In particular, the special types of student support required for e-learning and m-learning will have to be developed further within the MNU structure. The range and speed of tasks that can be performed through technology is likely to expand sharply in the future, and the MNU can exploit the potential of technology. The Center for Open Learning, in particular, can play a key role in the delivery of higher education to the provinces and atolls. Second, the MNU will have to introduce new degree programs and courses, wherever relevant and necessary. Third, the non-degree programs and courses may need to be shed, over time, and left to either the Polytechnic or the private sector. Fourth, over the long-term the MNU has to generate research capacity and output.

Figure 3.3. Distribution of MCHE Graduates by Type of Academic Award in 2008/2009

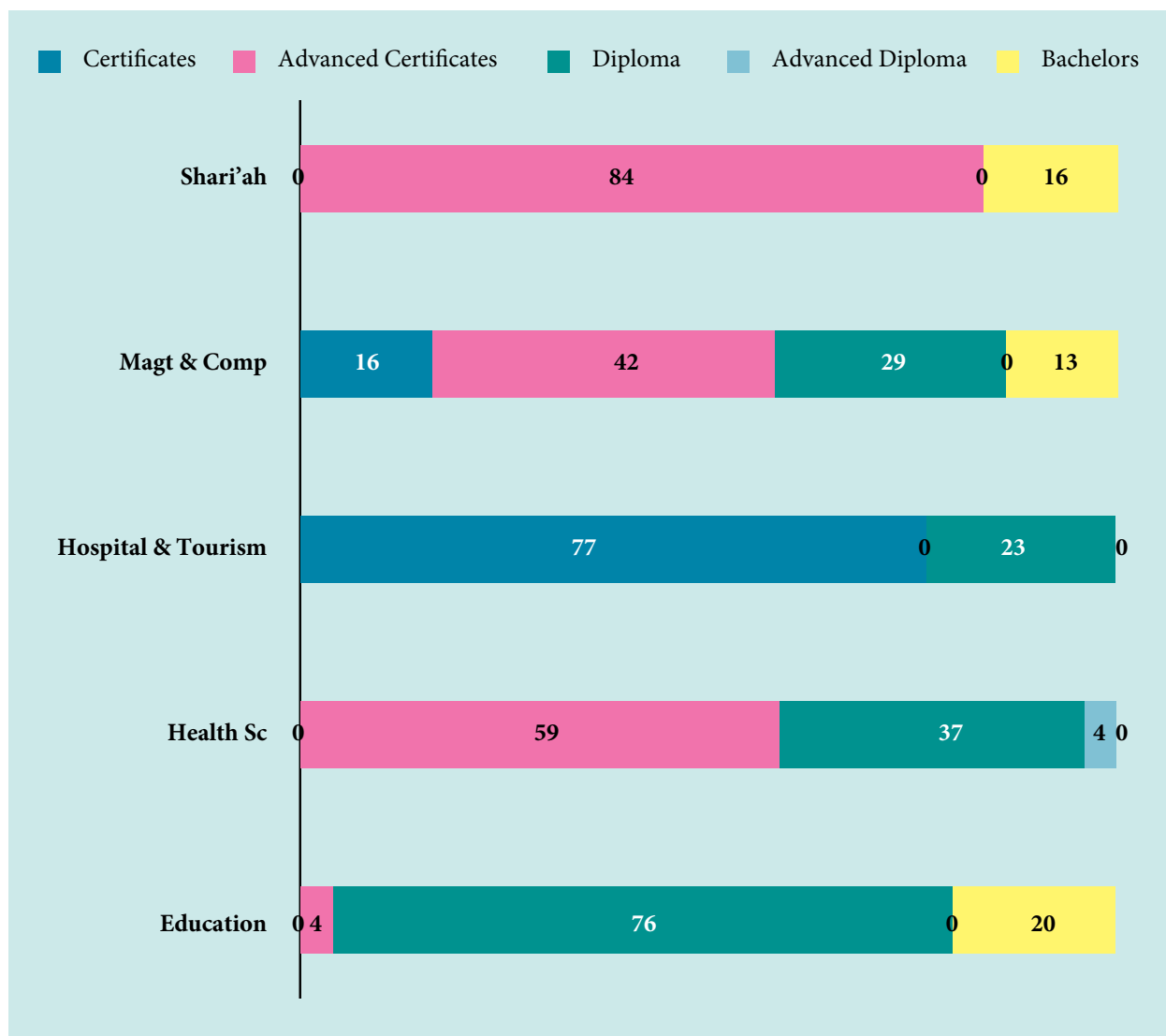

Source: MCHE statistics, 2008/2009.

- 3.39. The future development of the MNU could also involve the following key initiatives:
- **Organizational review:** The executive management of MNU would need to complete a review of its organizational structure against a background of mission, mandate, values and development commitments. The resultant organizational structure should be fully documented with functional responsibilities, accountabilities, performance standards, staffing levels, and position descriptions.
  - **Establishing new academic faculties where required:** for instance, a new faculty in the area of applied sciences. The Faculty of Applies Sciences would have a focus on relevant areas of science for the Maldives including marine science, environmental studies, and green energy.

### **Box 3.1. Relevance of Higher Education and Training to Employment, the University of Belize (UB)**

The University of Belize (UB) is a national, autonomous and multi-location institution committed to excellence in higher education, research and service for national development. As a catalyst of change it provides relevant, affordable and accessible educational and training programs that address national needs based on principles of academic freedom, equity, transparency, merit and accountability. The University of Belize is dedicated to fostering Belize's development by producing graduates who are socially and ecologically responsible, analytical, self-confident, disciplined, ethical, entrepreneurial, and skilled communicators and who are committed to using these skills and values for Belize's enrichment.

The Faculty of Management and Social Sciences (FMSC), for example, focuses on quality graduates, who have the knowledge and competencies to find employment in sectors relevant to their field of study. It is expected that all graduates will have a well-rounded education and will be technically and professionally qualified in their area of studies. Graduates at this level will be expected to take up leadership positions in middle level and upper level management of organizations and also be expected to have tools that will lead them towards creating their own businesses. Graduates will also be well equipped with the requisite academic skills to transfer successfully into graduate programs. Associate degree students will also boast a well-rounded education and be equipped with the necessary skills to function effectively and efficiently at the beginning levels of organizations. These graduates will also be well equipped to transfer easily into undergraduate degree programs.

The FMSC offers the following programs: (i) Certificate in Para-Legal Studies (CPLS), (ii) Associate Degree, Business Science (ABUS), (iii) Associate Degree, Tourism Studies (ATOS), (iii) Bachelor Degree, Accounting (BACC); (iv) Bachelor Degree, Public Sector Management (BPSM), (v) Bachelor Degree, Management (BMAN), (vi) Bachelor Degree, Tourism Management (BTOM). Partnership with employers, especially from the private sector is important and allows for funding for particular projects or support for specific programs. The FMSC at UB has successfully received support for specific programs from targeted employers. For example, the tourism programs have been embraced by the tourism sector and hotel chains and operators have provided opportunities for internships for UB students. The paralegal program is supported through the Belize Bar Association in terms of adjunct faculty who provide their services for nominal fees and pro bono.

### Box 3.2. Distance and Flexible Learning (DFL) at the University of South Pacific (USP)

The University of South Pacific (USP) is a regional university established to serve 12 small island states spread out over vast distances in the Pacific Ocean. The fact that USP has accomplished this feat is a testament to perseverance and to taking advantage of developments in the field of international communications technology. At present, more than half of the university's 22,000 students are distance students; that is, in the modern jargon, they are distance and flexible learning (DFL) students who learn with the assistance of modern telecommunications media, comprising audio conferencing, videoconferencing, and the Internet, as well as paper-based materials. The communication difficulties facing the small communities living on the small outlying islands and in the remote areas of the main islands have long been a concern for Pacific peoples. The advent of global satellite coverage and the rapidly declining costs of computers and VSAT (very small aperture terminals) equipment, together with the availability of solar power technology, have opened up the possibility for people in the remote communities to have immediate telecommunications contact with the rest of the world. This technology also opens up the opportunity for these communities to participate in the DFL offerings of **USPNet**. It is likely that the next big step for USPNet will be to develop its facilities to respond to this demand.

#### The Lessons Learned from the USPNet Experience

- **Strong, consistent leadership at the top of the organization** is needed to drive the project over the long term. The USPNet project has greatly benefited from having vice chancellors who have given it high priority for resources. They have provided a clear vision for the project and have been champions who were able to convince aid donors to fund the various stages of development.
- **A highly participatory approach to project design and implementation** builds commitment and support for the project by the stakeholders. For the USPNet project, senior management from the outset adopted consultative decision-making processes on project design issues, especially those related to the priorities of the users, and put in place a system to gain regular feedback on USPNet performance from the clients located across the 12 campuses. The campus directors are major clients of the educational services delivered through USPNet. A system that ensures regular feedback and consultation on the needs of the clients and the extent to which USPNet is meeting those needs is necessary to gain the full support and ownership of the project.
- **Clarity as to the roles and responsibilities of all persons responsible for implementation.** Reaping the educational benefits of the USPNet project has been somewhat delayed by lack of a unified organizational structure for project management that coordinated the roles of the main groups that make the project successful: the academic staff members in the faculties; the 12 USP campus directors; and the Information Technology Services Division, the Centre for Educational Development and Technology, and the Distance and Flexible Learning Support Centre.

- **Establishment of MNU Net:** The executive management of MNU would need to develop a strategic plan for the establishment of MNU Net as a cost-effective regional communications system for campus administration and distance education program delivery similar in spirit and approach to the successful e-based distance learning network used by the University of South Pacific USPNet [see Box 3.2].
- **New Academic Framework:** The executive management of MNU would also need to develop a unified university-wide approach to develop guidelines and processes for new program design, delivery and evaluation. The framework would also involve the shifting of most sub-degree programs to the Maldives Polytechnic (MP), and the definition of all program articulation arrangements using the guidelines of the Maldives National Qualification Framework (MNQF).

### **Social benefits of higher education: the MNU and the promotion of democracy in the Maldives**

3.40. The political processes in the Maldives have been evolving over time. Originally a Sultanate even as recently as the mid-twentieth century, the country became a Presidential system in the second half of the twentieth century. Multi-party democracy was finally established in the twenty-first century. As such, modern liberal democracy is in its infancy in the Maldives. It is vitally important that the Maldives cultivates an enlightened citizenry, with the ethics, values, norms and codes of conduct required for democracy to be established strongly and sustainably. The MNU can play an important role in this context.

3.41. **The MNU needs to be at the center of policy measures to promote democracy through higher education.** The Faculty of Arts and Humanities clearly has a key role to play, through its courses and programs in the social sciences and politics, in deepening the understanding of political democracy among its students. Beyond this, however, the MNU could consider introducing, for students following courses and programs in other Faculties, modules that cover the history of democratic reform and the evolution of democracy in the world and in the Maldives, and the desirability of the institutions of democracy, including such concepts as the separation of powers between the executive, the legislative and the judiciary, systems of checks and balances on the exercise of power, and an independent media. It is also extremely important that students understand and appreciate the important values and processes of democracy, such as personal freedoms, human rights, political and civic responsibilities of individuals, reasoned debate and argument, participatory decision-making, and non-violent conflict resolution. These modules would build upon the foundation established in the secondary education curriculum, but rise well above it. This is particularly important in the Maldives because a large number of students actually complete schooling at the age of 15 years, and enter the MNU or other HEIs to follow certificate and diploma level courses. A greater understanding of civics and democratic governance is possible for students in their late teens and beyond, compared to the cognitive levels of students in their mid-teen years. Such modules also need to count towards the credit received by students, to ensure that all students have an incentive to follow these modules fully.

## THE MALDIVES POLYTECHNIC (MP)

3.42. The MP has developed its programs drawing on lessons from international practices, and with some feedback from industry and business. The academic organization and awards of the MP are presented in Figure 3.4. The mandate of the MP includes both short-cycle diplomas and certificates, as well as some applied degree programs in selected disciplines.

Figure 3.4. The Academic Organization and Awards of the Maldives Polytechnic (MP)

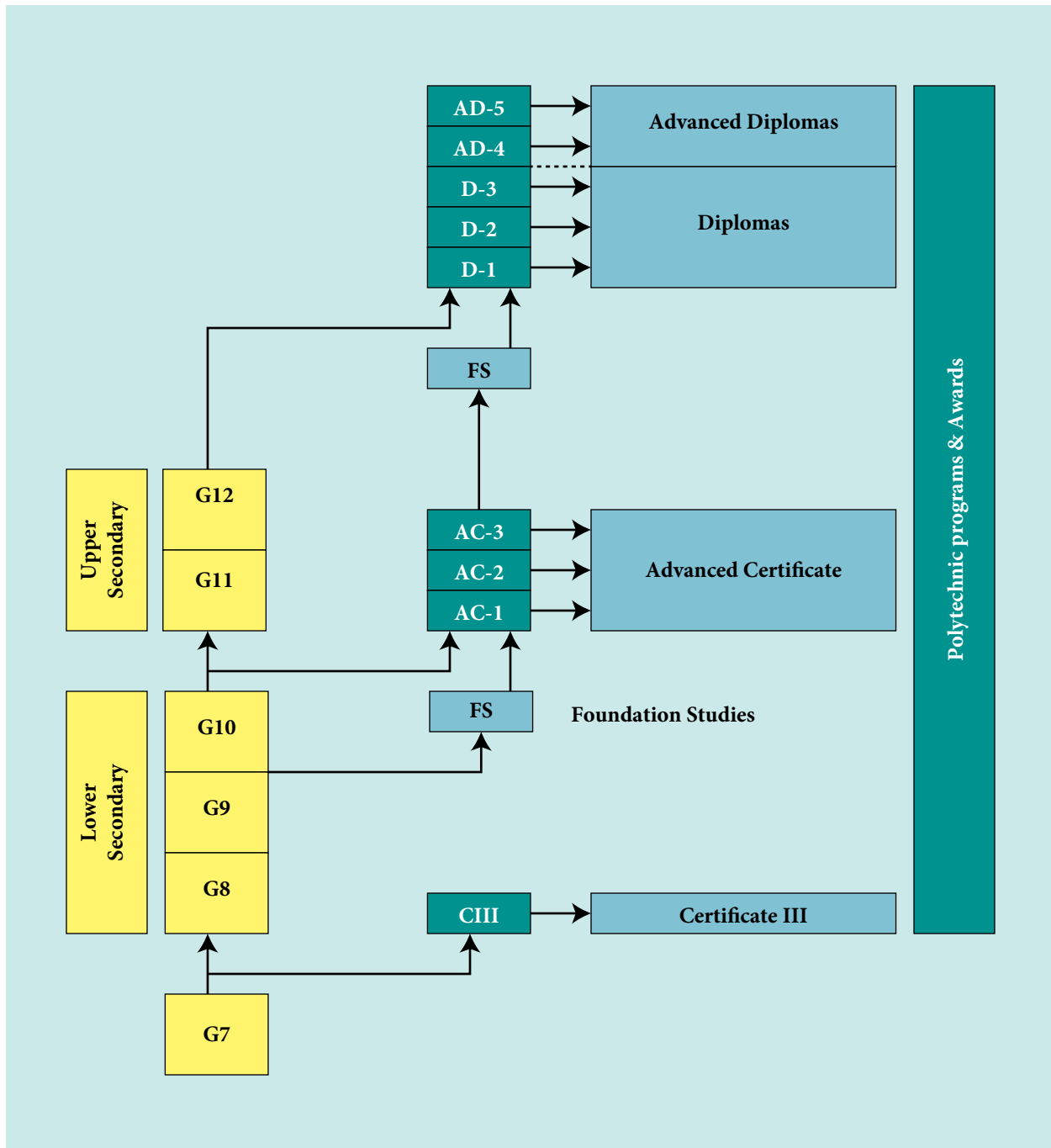

3.43. The developments in modern technology and communications, changing skills requirements for economic production processes, and the new sub-degree programs that will have to be transferred from the former MCHE to the MP, means that the Polytechnic now needs a program development and renewal framework that is suited to the requirements of the Maldivian economy. Further, the existing learning resources in the Polytechnic need considerable strengthening. In particular, the relevance of higher education in knowledge-intensive technological fields requires the effective use of resources, frequent upgrading and refurbishing of equipment and facilities, and regular and continuing staff development.

3.44. **The MP will have to develop in ways that enable it to produce graduates who have skills that are relevant in a rapidly evolving and changing labor market.** There are a number of steps that the Polytechnic can take to develop as a modern, high-performing institution. In particular, to ensure the quality and continued relevance of programs, and to establish a student-centered learning environment.

3.45. **The MP needs to have a close link with the world of work by having active Program Advisory Committees (PACs) composed of successful practitioners from various sectors of the economy who employ graduates of the MP programs.** The quality of programs of the MP and in the private institutions of higher education and training should be informed by ongoing the advice and input from these PACs. On-going links and input from key employers in relevant sectors of the economy is a necessary condition for relevance to the labor market in modern times. At present these formal partnerships and linkages with employers do not represent a key element of the institutional culture of the MP, and needs to be revitalized and developed. The effective use of PACs would require the following types of measures:

- The composition of the PACs should have a balanced representation from key employers in the sector, as well representatives of the sector employment councils.
- Mandating the PACs to provide oversight and approval of all changes to existing programs and for the establishment of new programs.
- The government could consider establishing incentives to encourage employers to participate in work-study cooperative schemes in which students can alternate semesters of study at the HEI with semester of employment and training with the employers.

3.46. **The MP could also be encouraged to explore the use of ICT (Information and Communication Technology) platforms and on-line internet technologies to support the effective delivery of their programs.** The use of ICT and web-based technologies to support teaching, which at present is less than adequate in most academic units of the Polytechnic, would be extremely useful. This will also require staff developments programs to enable academic staff to strengthen their skills to use ICT platforms and on-line programs as an integral part of their teaching strategies.

3.47. **Increase the capacity, quality and relevance of sub-degree programs in hospitality and tourism studies, construction and fisheries.** These are key economic sectors in the Maldives, and are likely to grow over time, especially tourism and construction. As such, these sectors will generate a continuous flow of demand for skilled personnel. The MP can play an active role in meeting this demand, at the levels of skills within its mandate.

# APPENDIX A

## Public Higher Education Institutions

### (1) The Maldives National University (former Maldives College of Higher Education [MCHE])

#### *Enrolment and Graduation levels in MCHE in 2008/2009*

In the academic year 2008/2009, there are 4,550 total enrolments (See Table A1). The main distinguishing characteristics of the pattern of enrollment and graduation from MCHE<sup>9</sup> are that: (a) about 60 percent of students are female; and (b) education, management and computing, and health sciences are the most popular subjects. The high rates of female enrollment are normal in education systems as they advance. In neighboring Sri Lanka, too, university enrollment is about 60 percent or more female. A similar pattern can be observed in many more developed countries, too. The popularity of subjects such as education and health sciences will also be related to high female enrollment, as these are sectors which are popular among female workers.

**Table A1. Enrolment Levels and Numbers of MCHE Graduates in the Academic Year 2008/2009**

Faculty	Enrolment 2008-09			Graduates 2008-09		
	F	M	Total	F	M	Total
Centre for Maritime Studies	0	0	0	0	0	0
Centre for Open Learning	91	421	512	20	68	88
Faculty of Shari'ah and Law	117	138	255	2	4	6
Faculty of Hospitality and Tourism Studies	118	236	354	50	87	137
Faculty of Education	1170	405	1575	265	96	361
Faculty of Health Sciences	596	109	705	211	36	247
Faculty of Management and Computing	458	510	968	114	104	218
Foundation Studies	146	35	181	27	94	121
<b>Total MCHE</b>	<b>2696</b>	<b>1854</b>	<b>4550</b>	<b>689</b>	<b>489</b>	<b>1178</b>

Source: MCHE statistics.

Notes: F = female, M = male. The CMS delivers short courses only.

#### *The Faculty of Education (FE)*

The Faculty of Education, initially known as the Institute for Teacher Education is one of the key faculties at MCHE. Initial efforts at teacher education in the Maldives were aimed at training teachers in Dhivehi to provide basic education in primary schools. With universal primary education achieved, FE embarked on training teachers for secondary education in 1997. The provision of teacher education in the atolls is a major initiative of the Faculty of Education.

<sup>9</sup> This section uses the terms Maldives College of Higher Education and MCHE rather than Maldives National University or MNU because the data pertains to the period when the institution was still the Maldives College of Higher Education (MCHE).

FE Diplomas and Certificates	FE Degrees
<ul style="list-style-type: none"> <li>• Advanced Diploma n Applied Statistics</li> <li>• Diploma in School Management</li> <li>• Diploma in Teaching English as a Foreign Language</li> <li>• Diploma teaching Dhivehi Language</li> <li>• Advanced Certificate in Teaching-Primary</li> <li>• Diploma in Teaching-Primary School</li> <li>• Diploma in Teaching-Middle School</li> <li>• Diploma in Teaching-Secondary School</li> </ul>	<ul style="list-style-type: none"> <li>• BA in Dhivehi Language</li> <li>• Bachelor of Education-Primary Schools</li> <li>• Bachelor of Education- Secondary Schools</li> <li>• BA in Teaching English as a Foreign Language</li> </ul>
Source: MCHE.	

The number of enrolled and graduating students in the Faculty of Education in the academic year 2008-2009 is outlined in Table A2.

**Table A2. The Number of Students and Graduates in the Faculty of Education in the Academic Year 2008-2009**

Faculty	Award	Enrolment 2008-09			Graduates 2008-09		
		F	M	Total	F	M	Total
<b>Faculty of Education FE</b>							
Applied Statistics	AD	7	10	17	1	0	1
School Management	D	10	12	22	4	6	10
Dhivehi Language	BA	57	34	91	0	0	0
Teaching English as a Foreign Language	D	45	6	51	19	3	22
Primary Education	BA	55	9	64	12	0	12
Dhivehi Language	D	93	54	147	47	36	83
Teaching English as a Foreign Language	BA	73	21	94	12	0	12
Teaching Primary Schools	AC	19	6	25	15	1	16
Teaching Middle Schools	D	128	29	157	26	8	34
Teaching Secondary Schools	D	165	66	231	60	20	80
Teaching Primary Schools	D	256	29	285	40	4	44
Teaching Secondary Schools	BA	262	129	391	29	18	47
<b>Total Faculty of Education</b>		<b>1170</b>	<b>405</b>	<b>1575</b>	<b>265</b>	<b>96</b>	<b>361</b>

Source: MCHE statistics.

### ***The Faculty of Health Sciences (FHS)***

The FHS was originally established as the Allied Health Services Training Centre (AHSTC) in 1973 under the Ministry of Health. Its status was upgraded to the Institute of Health Sciences (IHS) in 1991, and finally consolidated with other institutions with formation of the MCHE and renamed as the Faculty of Health Sciences (FHS) in 2001. The Faculty conducts a range of training programs in the field of primary care, nursing, pharmacy and medical lab technology to meet the health care demands in the Maldives. The FHS provides pre-service, and in-service education through workshops and seminars in the Male' and the atolls.

<b>FHS Diplomas and Certificates</b>	<b>FHS Degrees</b>
<ul style="list-style-type: none"> <li>• Advance Certificate in Primary Health Care</li> <li>• Advance Certificate in Counseling</li> <li>• Advance Certificate in Family Health</li> <li>• Advance Certificate in Nursing</li> <li>• Advance Certificate in Pharmacy</li> <li>• Certificate III in Social Services</li> <li>• Diploma in Critical Care Nursing</li> <li>• Diploma in Medical Laboratory Technology</li> <li>• Diploma in Nursing</li> <li>• Advanced Diploma in Nursing</li> <li>• Diploma in Primary Health Care</li> </ul>	<ul style="list-style-type: none"> <li>• Bachelor of Nursing</li> </ul>
Source: MCHE statistics.	

The number of enrolled and graduating students in the FHS in the academic year 2008-2009 is outlined in Table A3. Similar patterns can be observed in the data concerning the enrolment and graduation in the Faculty of Health Sciences, to those observed in the Faculty of Education including: (a) the ratio of enrolled females to enrolled males exceeds 5:1 and the ratio of female to male graduates is close to 6:1, (b) the vast majority of all graduates are in sub-degree (certificates, advanced certificates, diplomas and advanced diplomas) programs, and (c) there are no enrolments of students in post graduate programs.

**Table A3. The Number of Students and Graduates in the Faculty of Health Sciences in the Academic Year 2008-2009**

Faculty	Award	Enrolment 2008-09			Graduates 2008-09		
		F	M	Total	F	M	Total
<b>Faculty of Health Sciences</b>							
Social Services Work	CIII	0	1	1	0	0	0
Primary Health	AC	47	39	86	17	9	26
Counselling	AC	20	2	22	7	1	8
Family Health	AC	14	3	17	12	3	15
Nursing	AC	151	0	151	66	0	66
Pharmacy	AC	16	0	16	4	0	4
Social Work Services	AC	32	3	35	22	5	27
Medical Lab Technology	D	42	8	50	10	2	12
Nursing	DN&ADN	147	1	148	31	1	32
Nursing (Conversion)	DN	13	0	13	11	0	11
Pharmacy	D	11	6	17	4	0	4
Primary Health Care	D	13	12	25	4	10	14
Primary Health Care (Conversion1)	D	11	5	16	11	5	16
Primary Health Care (Conversion3)	D	15	13	28	0	0	0
Midwifery	D	41	0	41	15	0	15
Health Services Management	BSc	22	16	38	0	0	0
Nursing	BN	1	0	1	1	0	1
<b>Total Faculty of Health Sciences</b>		<b>596</b>	<b>109</b>	<b>705</b>	<b>215</b>	<b>36</b>	<b>251</b>

Source: MCHE statistics.

### ***The Faculty of Hospitality and Tourism Studies (FHTS)***

The Faculty was originally established in 1987 as the School of Hotel and Catering Services under the Ministry of Tourism to develop trained personnel for the tourism sector. The school was transferred to MCHE and given its present name in 2001. FHTS was initially the only independent centre in the Maldives offering programs of the Business and Technical Education Council (BTEC) qualifications by a Foundation in the UK. The Faculty is unique in that respect in its ability to offer these qualifications in the Maldives.

<b>FHST Diplomas and Certificates</b>	
<ul style="list-style-type: none"> <li>• BTEC National Diploma (ND) in Catering and Institutional Operations</li> <li>• BTEC National Diploma (ND) in Travel and Tourism</li> <li>• Certificate III in Accommodation Operations</li> <li>• Certificate III in Food and Drinks Services</li> <li>• Certificate III in Commercial Cookery</li> <li>• Certificate III in Front Office Operations</li> <li>• Certificate III in Pastry and Bakery</li> </ul>	<ul style="list-style-type: none"> <li>• Bachelor of Nursing</li> </ul>
Source: MCHE statistics.	

The number of enrolled and graduating students in the Faculty of Hospitality and Tourism Studies in the academic year 2008-2009 is outlined in Table A4. Three key observations can be made here. First, the enrolment numbers are low compared to those found in education or health science. Second, the enrolment of males is almost double those of females probably reflecting the resistance to the employment of females in the tourism sector in the Maldives. Finally, all the programs in this sector are at the sub-degree levels; i.e. certificates and diplomas.

**Table A4. The Number of Students and Graduates in the Faculty of Hospitality and Tourism Studies in the Academic Year 2008-2009**

Faculty	Award	Enrolment 2008-09			Graduates 2008-09		
		F	M	Total	F	M	Total
<b>Faculty of Hospitality and Tourism</b>							
BTEC in Hotel Catering & Operations	ND	4	47	51	1	13	14
BTES in Travel & Tourism	ND	19	31	50	11	6	17
Accommodations & Operations	CIII	2	2	4	0	20	20
Food & Drink Service	CIII	3	31	34	1	15	16
Commercial Cookery	CIII	7	4	11	11	4	15
Front Office Operations	CIII	55	64	119	24	29	53
Pastry & Bakery	CIII	6	3	9	2	0	2
<b>Total Faculty of Hospitality and Tourism</b>		<b>96</b>	<b>182</b>	<b>278</b>	<b>50</b>	<b>87</b>	<b>137</b>

Source: MCHE statistics.

### ***The Faculty of Management and Computing (FMC)***

The Faculty of Management and Computing (FMC) was originally established in 1991 as the Maldives Centre for Management and Administration (MCMA). The centre joined MCHE and its status was upgraded to an Institute and renamed the Institute of Management and Administration (IMA) in 1998. Finally the IMA was given the status of a Faculty and renamed once again to its present name as the Faculty of Management and Computing in 2001. The Faculty offers a wide range of programs in business management and information technology and the certificate, diploma and degree levels.

<b>FMC Diplomas and Certificates</b>	<b>FMC Degrees</b>
<ul style="list-style-type: none"> <li>• Advanced Certificate in Island Administration</li> <li>• Advanced Certificate in Accounting</li> <li>• Advanced Certificate in Management</li> <li>• Advanced Certificate Information Technology</li> <li>• Advanced Diploma in Accounting</li> <li>• Advanced Diploma Information Technology</li> <li>• Advanced Diploma in Business and Commerce</li> <li>• Certificate III in Clerical Studies</li> <li>• CIMA Certification</li> <li>• Diploma in Accounting</li> <li>• Diploma in Business</li> <li>• Diploma in Information Technology</li> </ul>	<ul style="list-style-type: none"> <li>• Bachelor of Information Technology</li> <li>• Bachelor of Business</li> <li>• Chartered Accountancy Part 1</li> <li>• Chartered Accountancy Part 2</li> </ul>
Source: MCHE statistics.	

The number of enrolled and graduating students in the Faculty of Management and Computing in the academic year 2008-2209 is outlined in Table A5.

**Table A5. The Number of Students and Graduates in the Faculty of Management and Computing in the Academic Year 2008-2009**

Faculty	Award	Enrolment 2008-09			Graduates 2008-09		
		F	M	Total	F	M	Total
<b>Faculty of Management and Computing</b>							
Island Administration	AC	5	24	29	15	51	66
Information Technology	AD	1	1	2	2	0	2
Accounting	AC	3	2	5	1	4	5
Management	AC	41	26	67	10	9	19
Accounting	AD	1	7	8	0	0	0
Business & Commerce	AD	1	1	2	0	0	0
Information Technology	AC	1	1	2	0	0	0
Information Technology	BA	11	31	42	2	8	10
Business Management	BA	33	10	43	15	4	19
Clerical Studies	CIII	37	10	47	31	4	35
Chartered Accountancy	ACCA2	0	8	8	0	0	0
Chartered Accountancy	ACCA1	29	39	68	0	0	0
CIMA	CIMA	2	3	5	0	0	0
Accounting	D	56	79	135	5	6	11
Business Management	D	75	48	123	24	10	34
Information Technology	D	45	85	130	9	8	17
<b>Total Faculty of M&amp;C</b>		<b>341</b>	<b>375</b>	<b>716</b>	<b>114</b>	<b>104</b>	<b>218</b>

Source: MCHE statistics.

The pattern of enrolment and graduation in the Faculty of Management and Computing is more equitable among males and females as well as the distribution of these numbers among the various programs and program academic awards compared to other Faculties at MCHE.

### ***The Faculty of Shari'ah and Law (FSL)***

The Faculty of Shari'ah and Law (FSL) previously known as the Institute of Shari'ah and Law was established in 1999 to strengthen the legal and judicial system of the Maldives by producing suitably qualified personnel qualified in legal and judicial affairs. The primary function of FSL is to design, develop and deliver courses in Shari'ah and Law at the certificate, diploma and degree levels.

<b>FSL Diplomas and Certificates</b>	<b>FSL Degrees</b>
<ul style="list-style-type: none"> <li>• Advanced Certificate in Shari'ah and Law</li> <li>• Advanced Diploma in Shari'ah and Law</li> <li>• Diploma in Justice Studies</li> </ul>	<ul style="list-style-type: none"> <li>• Bachelor of Laws</li> <li>• Master of Arts in Shari'ah</li> </ul>
Source: MCHE statistics.	

The number of enrolled and graduating students in the Faculty of Shari'ah and Law in the academic year 2008-2009 is outlined in Table A6.

**Table A6. The Number of Students and Graduates in the Faculty of Shari'ah and Law in the Academic Year 2008-2009**

Faculty	Award	Enrolment 2008-09			Graduates 2008-09		
		F	M	Total	F	M	Total
<b>Faculty of Shari'ah &amp; Law</b>							
Shari'ah and Law	AC	53	35	88	14	17	31
Shari'ah and Law	AD	0	1	1	0	0	0
Law	BL-LLB	61	53	114	2	4	6
Justice Studies	D	2	43	45	0	0	0
Shari'ah and Law	MA	1	6	7	0	0	0
<b>Total Faculty of Shari'ah &amp; Law</b>		<b>117</b>	<b>138</b>	<b>255</b>	<b>16</b>	<b>21</b>	<b>37</b>

Source: MCHE statistics.

### ***The Center for Maritime Studies (CMS)***

The Center for Maritime Studies (CMS) was established in 1987 as the Maritime Training Centre (MTC), when the Maldives ratified the International Maritime Organization (IMO) conventions on standards of training, certification and watch keeping for seafarers. The Centre is located in Vilingili, separated by a narrow channel from Male'. The CMS has an important role in providing training for the national and international merchant navy service, as well as training for the fishing industry including courses for navigation and safety for fishermen.

### ***The Centre for Open Learning (COL)***

The Centre for Open Learning (COL) was established in 1999 as the Tertiary Institute for Open Learning (TIOL) to provide distance education programs at Foundation and Post Secondary levels.

Given the geography of the Maldives, distance education and open learning are cost effective and reliable modes of providing education services to the island communities in the atolls. The COL programs provide education opportunities to over 650 learners in 100 islands. The COL Programs include: (a) advanced certificate in primary teaching, and (b) English for Further Studies.

## (2) The Maldives Polytechnic

A summary of the student enrolment and the number of graduates from the various disciplines and specialties in engineering technology in the academic year 2007-2008 is presented in Table A7, which includes 30 distinct academic awards in four engineering and technology clusters: (a) mechanical engineering technology, (b) civil engineering and built environment technology, (c) electrical and electronic engineering technology, and (d) carpentry and boat building technology. The most popular subjects are mechanical engineering and electrical and electronic engineering. The course which has the highest enrollment is engine repair and maintenance.

**Table A7. Enrolment and Number of Graduates from the MCH Faculty of Engineering (now Polytechnic) in the Academic Year 2007-2008**

Faculty	Award	Enrolment 2008-09		Graduates 2008-09	
		F	M	F	M
<b>Mechanical Engineering</b>					
Mechanical Engineering	AD	0	0	0	0
Mechanical Engineering	D	0	9	0	2
Machining& Mechanical Fitting	C III	1	5	0	0
Engine Repair and Maintenance	AC	2	167	0	41
Fluid Power	AC	0	0	0	0
Refrigeration and Air Conditioning	AC	0	66	0	4
Welding & Metal Fabrication	AC	0	11	0	0
Engine Repair and Maintenance	C III	1	5	0	0
Welding & Sheet Metal	C III	1	17	0	4
<b>Total Mechanical Engineering</b>		<b>5</b>	<b>280</b>	<b>0</b>	<b>51</b>
<b>Civil Engineering &amp; Built Environment</b>					
Construction Management	AD	0	0	0	0
Civil Engineering	AD	1	10	0	1
Construction Management	D	0	0	0	0
Architecture	D	11	31	2	6
Civil Engineering	D	0	0	0	0
Building Construction	D	2	23	0	9
Desalination Sys O&M	AC	0	21	0	9
<b>Total Civil Eng &amp; Built Environment</b>		<b>14</b>	<b>85</b>	<b>2</b>	<b>25</b>

<b>Electrical &amp; Electronic Engineering</b>					
Electrical Engineering	AD	0	0	0	0
Electronic Engineering	AD	0	10	0	0
Electrical Engineering	D	0	0	0	0
Electronic Engineering	D	0	12	0	8
Electrical Engineering	AC	0	26	0	7
Electrical & Electronic Engineering	AC	1	105	0	23
Power System O&M	AC	0	41	0	6
<b>Total Elec &amp; Electronic Engineering</b>		<b>1</b>	<b>194</b>	<b>0</b>	<b>44</b>
<b>Carpentry</b>					
Furniture Carpentry & Joinery	AC	0	0	0	9
Wooden & Fibre Glass Boat Building	AC	0	27	0	25
Furniture Carpentry & Joinery	C III	0	28	0	15
Furniture Carpentry & Wood Carving	C III	0	0		
Wooden & Fibre Glass Boat Building	C III	0	0	0	25
<b>Total Carpentry</b>		<b>0</b>	<b>55</b>	<b>0</b>	<b>74</b>
<b>Total Engineering Technology</b>		<b>20</b>	<b>614</b>	<b>2</b>	<b>194</b>
Source: Maldives Polytechnic.					

# APPENDIX B

## Private Higher Education Institutions

***Clique College:*** Clique received college status in September 2009 after nine years of delivering higher education and training programs as Clique Training Centre. Clique's institutional capacity has expanded with the establishment of a library, larger academic staff portfolio, and quality assurance mechanisms. The College is planning to offer full degree pathways in four specialization; Business Management, Marketing, Tourism, and Human Resource Management. In addition, Clique offers accounting courses at the certificate level, and a diploma in Information Technology approved by the Maldives Qualifications Authority (MQA).

***Cyryx College (CC):*** CC is a full-fledged college that caters to over 3000 students and employs over 60 academic and support staff members. Its facilities have grown to include two campuses in Male' with several computer training labs, modern lecture rooms, and a library. CC, which originated as a computer training center, was awarded the "college" status by the government in 2009. The courses are approved by the MAB. CC is also among the private education providers in the Maldives which has developed its courses following the Maldives National Qualifications Framework (MNQF). CC has degree completion agreements with several universities in Australia, India and Malaysia.

***Focus Education Centre (FEC):*** FEC was established in 1995 as a training provider for computer studies. Today its portfolio includes programs, certificates and diplomas in business management, human resources management and IT applications including operating systems, networking and applications programming, as well as corporate IT systems.

***International Business Systems Overseas (IBS):*** IBS has been operating for about 15 years. It was incorporated as a Professional Higher Education Academy in 1996. IBS conducts certificate and higher diploma level programs in the fields of ICT, Management and Business Studies, and it is one of the largest private HEIs with multiple campuses on the atolls. IBS has also built strong partnership with the Edexcel International UK and its diploma programs in Information Technology (DIT), Software Engineering (DSE) and Business Administration (DBA).

***Mandhu College (MC):*** Mandhu College, initially established as Mandhu Learning Centre in 1998, offers higher education and training programs to lower and upper secondary school leavers. Further the College has opened avenues for adults without conventional secondary qualifications to obtain diplomas and degrees through its carefully structured Foundation programs as a bridging alternative to fill up the increasing gap between the shortage of competent personnel in various industries and the demand for these people. All programs offered by MC are approved by MAB/MQA. The Mandhu College programs include certificates, diplomas, advanced diplomas and graduate diplomas in the following subjects: early childhood education, teaching primary and

secondary education, business administration, and IT applications. MC also offers short courses at the level of Certificates I, II and III in wide range of applications.

**Modern Academy for Professional Studies (MAPS) College:** MAPS portfolio includes also seven programs geared towards professional certification with associations such as the Association of Chartered Certificate Accountants (ACCA), and the Association of Business Executive (ABE) of England.

- Diploma in Business Management, Marketing Management, Business Management, Travel, Tourism and Hospitality Management, and Human Resource Management;
- Graduate and Post Graduate Diploma in Hospitality and Tourism Management; and
- Certificates in Information Technology and Motion Graphics and Video Editing.

**Villa College:** Villa College is a full-fledged higher education and training institution belonging to the Villa Group. The colleges' programs include the following categories:

- Foundation/ Advanced Certificates in Information Technology, Teaching and Tourism Studies;
- Diplomas in Information Technology and Multimedia Technology;
- Bachelor Degrees in Information Technology, Multimedia Technology, Business Administration, Human Resources Management, Education (Education Administration, Mathematics and TESL) and Islamic Studies;
- Graduate Diploma in Teaching;
- Professional Certification Programs with CIM (Chartered Institute of Marketing) and ACCA (Association of Certified Chartered Accountants) in the UK; and
- Post Graduate Studies: Master of Business Administration, Master of Education, Graduate Diploma of Teaching.

## APPENDIX C

**Table C1. Indicators of Autonomy in Selected Countries**

Country/ Category	Netherlands	UK	Egypt	Canada	Maldives	Pakistan
Appointment / dismissal of VC/President/Rector	X	X		X		X
Appointment / dismissal of professors	X	X	X	X		X
Award academic tenure	X	X	X	X		X
Set academic pay and conditions				X		
Set students' entry standards		X		X	X	X
Selection of students		X		X	X	X
Decide size of enrollments	X	X		X		X
Quotas for special groups	X	X		X	Part	
Decide language of instruction		X		X	X	X
Introduction of new courses / elimination of old courses	X	X	X	X	X	X
Selection of textbooks	X	X	X	X	X	X
Set examination / graduation standards	X	X		X	X	X
Decision to teach courses at graduate level	X	X	X	X	X	X
Set research priorities	X	X	X	X	X	X
Approval of publications	X	X	X	X	X	X
Select members of governing council / board		X	X	X		
Management of university budget	X	X	X	X	Part	X
Set level of tuition fees		Part			Part	
Approval of income generating ventures	X	X	X	X		X
Buy or sell buildings and equipment	X	X		X		X
Ability to borrow funds from a bank	X	X		X		X

Source: World Bank surveys conducted in 2005-10 from JF/JS data.

Note: X means that the university is autonomous in this area.

**Table C2. The Maldives National Qualification Framework (MNQF)**

Level and Academic Awards	Generic and Applied Knowledge & Skills	Communication and ICT Skills	Autonomy, Accountability and Team Work
Level 1: Certificate I	<ul style="list-style-type: none"> <li>Relate basic knowledge in subject/discipline to personal and/or work context</li> <li>Use routine skills (fewer in Level 1) in to complete familiar and routine (Level 1) tasks</li> <li>Select (Level 2) or use with guidance basic (Level 1) tools and materials safely and effectively</li> <li>Identify, with some prompting, a process relevant to the task at hand (Level 1)</li> <li>Use, with guidance (Level 2) designated stages of a problem solving strategy to deal with a situation or issue</li> </ul>	<ul style="list-style-type: none"> <li>Use simple written, oral communication skills in routine contexts</li> <li>Carry out and use simple data processing tasks</li> </ul>	<ul style="list-style-type: none"> <li>Work alone or with others under frequent supervision</li> <li>Participate in the setting of goals and the review of completed work</li> <li>Participate in the identification of ways of improving work practices</li> </ul>
Level 2: Certificate II			
Level 3: Certificate III	<ul style="list-style-type: none"> <li>Relate (Level 3) or apply (Level 4) knowledge in subject/discipline to personal and/or work context</li> <li>Complete routine (Level 3), or non-routine (Level 4) tasks using knowledge associated with subject or discipline</li> <li>Select, (Level 3) or plan (Level 4) to use, and adjust, appropriate tools and materials safely and effectively</li> <li>Use (Level 3) or organize (Level 4) abstract constructs to make generalizations or draw conclusions</li> </ul>	<ul style="list-style-type: none"> <li>Use a range of written, oral communication skills</li> <li>Use standard applications to obtain, process information</li> </ul>	<ul style="list-style-type: none"> <li>Work alone or in teams , and take leadership responsibility (Level 4) for task completion</li> <li>Participate , and take leadership in the identification of ways of improving work practices</li> </ul>
Level 4: Certificate IV			
Level 5: Diploma	<ul style="list-style-type: none"> <li>Demonstrate a broad and sometimes detailed (Level 6) knowledge of the subject/discipline</li> <li>Awareness of the changing nature of the body of knowledge, as well as the areas of scholarly research in the discipline (Level 6)</li> <li>Use a range of routine, and advanced (Level 6) techniques to evaluate evidence-based solutions to work-related problems</li> <li>Use a range of approaches to addressing (Level 5) or formulating (Level 6) responses to routine problems</li> </ul>	<ul style="list-style-type: none"> <li>Use a range (Level 6) of standard applications to obtain and process information</li> <li>Use a range (Level 5) of data management skills</li> </ul>	<ul style="list-style-type: none"> <li>Manage limited (Level 5) resources within defined areas of work</li> <li>Take continuing (Level 6) account of own and others roles, responsibilities and contributions</li> </ul>
Level 6: Advanced Diploma, Professional Associate Degree, or Foundation Degree			
Level 7: Bachelor Degree	<ul style="list-style-type: none"> <li>Demonstrate critical understanding of a selection (Level 7) of principal theories and concepts of the discipline</li> <li>Use a selection (Level 7) or a range (Level 8) of principal skills, techniques practices or materials associated with the discipline</li> <li>Apply (Level 7) routine methods of enquiry or research, or execute a defined project of research and development (Level 8)</li> <li>Identify and analyze routine professional problems (Level 7) or critically review and consolidate associated knowledge (Level 8)</li> </ul>	<ul style="list-style-type: none"> <li>Use a wide (Level 8) range of skills to support established work practices</li> <li>Use range of software and IT applications</li> </ul>	<ul style="list-style-type: none"> <li>Exercise autonomy and initiatives in some (Level 7) professional activities</li> <li>Work under guidance (Level 7) with qualified practitioners</li> <li>Deal with professional and ethical challenges</li> </ul>
Level 8: Post Graduate Certificate or Diploma, Advanced Professional Diploma and Honors Degree			
Level 9: Masters Degree	<ul style="list-style-type: none"> <li>Demonstrate a critical detailed and leading (Level 10) knowledge and understanding of the forefront of the discipline</li> <li>Plan (Level 9), or design (Level 10) a significant project of research and development in the discipline</li> <li>Identify, conceptualize and offer creative responses (Level 9) and/or insights (Level 10) into challenging disciplinary problems and issues</li> </ul>	<ul style="list-style-type: none"> <li>Use a wide range of software to support and enhance research and investigations</li> </ul>	<ul style="list-style-type: none"> <li>Exercise substantial autonomy and initiatives in professional activities</li> <li>Make informed judgment on ethical and professional issues</li> </ul>
Level 10: Doctoral Degree or Higher Professional Diploma			

# BIBLIOGRAPHY

Bashir, Sajitha. (2007). *Trends in International Trade in Higher Education*. Education Working Paper Series, HDNED, the World Bank, Washington D.C., U.S.A.

Bloom, David, David Canning, and Kevin Chan. (2006). *Higher Education and Economic Development in Africa*. Human Development Sector, Africa Region, The World Bank, Washington D.C., U.S.A.

Fielden, John. (2008). *Global Trends in University Governance*. Education Working Paper Series, HDNED, the World Bank, Washington D.C., U.S.A.

Government of Maldives. (2009a). *The Other Maldives*.

Government of Maldives. (2009b). "Facing Global and Local Challenges: The New Dynamics of Higher Education". *Maldives: Country Report. Sub-regional Preparatory Conference for the 2009 UNESCO World Conference on Higher Education*.

Hanushek, Eric and Finis Welch. (2006), *Handbook of the Economics of Education* Volume 1. Elsevier Science and Technology Books.

Hill, Kent, Dennis Hoffman, and Tom R. Rex. (2005). *The Value of Higher Education: Individual and Societal Benefits*. L. William Seidman Research Institute, W.P. Carey School of Business, Arizona State University.

Maldives College of Higher Education. (2006). *Teaching and learning development Plan: 2006-2008*. Male', Maldives: Maldives College of Higher Education.

Maldives College of Higher Education. Statistics, various years.

Mazeran, Jacques, Experton William, Christian Forestier, André Gauron, Serge Goursaud, Albert Préévos, Jamil Salmi, and Francis Steier. (2007). *Short-Term Vocational Higher Education: A Global Challenge in Education*. Hachette Education, Paris.

McMahon, Walter. (2009). *The Private and Social Benefits of Higher Education: Higher Learning, Greater Good*. Baltimore: The Johns Hopkins University Press.

Mikhail, Samih. (2008). *The Alternative Tertiary Education Sector: More Than Non-University Education*. Education Working Paper Series, HDNED, the World Bank, Washington D.C., U.S.A.

Ministry of Education. *School Statistics*, various years. Male', Maldives.

Ministry of Planning and National Development. (2009). *Maldives at a Glance*. Male', Maldives.

Saint, William, Christine Lao, and Peter Materu. (2009). *Legal Frameworks for Tertiary Education in Sub-Saharan Africa: The Quest for Institutional Responsiveness*. The World Bank, Washington D.C., U.S.A.

Salmi, Jamil. (2009). *The Challenge of Establishing World-Class Universities*. The World Bank, Washington D.C., U.S.A.

Salmi, Jamil. (2011). *The Road to Academic Excellence*. The World Bank, Washington D.C., U.S.A.

Woodhall, Maureen. (2007). *Funding Higher Education: The Contribution of Economic Thinking to Debate and Policy Development*. Education Working Paper Series 8. The World Bank, Washington D.C., U.S.A.

World Bank. (2002). *Constructing Knowledge Societies: New Challenges for Tertiary Education*. The World Bank, Washington D.C., U.S.A.

Zubair, Shafeea. (2009). *Maldives Institute of Vocational Education and Training*.





The World Bank  
1818 H Street, NW  
Washington, DC 20433  
USA  
Telephone: 202-473-1000  
[feedback@worldbank.lk](mailto:feedback@worldbank.lk)  
[www.worldbank.org](http://www.worldbank.org)



The World Bank  
Maldives Country Office  
2nd Floor, Hithigasdhoshuge Aage  
Hakuraa Goalhi, Henveiru  
Male' 20094, Republic of Maldives.  
Telephone: +960 334 1909-10  
Facsimile: + 960 334 1911

**ISBN : 978-955-8908-42-6**